

# ARCHITECTURAL/ THEATRICAL LIGHTING

Catalog Number  
**SS-STRIP-\*.\*\*.\*\*\***

Fixture Type:



The SPECTRA STRIP is a low profile 6' LED Linear Wash Luminaire with (12) compartments of 50w RGBA Color Mixing or 3000°K high CRI White Light LED Engines. Each compartment can be individually filtered, lensed, or diffused using the dual filter slots provided per compartment.

White light compartments are suitable for no color wash applications, as well as tinting the RGBA Light engines in a blended wash. Additionally, White Light compartments can be used with traditional color media.

Suitable for both Floor and Pipe mounted applications, the low-profile SPECTRA STRIP is a capable LED Replacement for traditional Theatrical Strip Lights, Foot Lights, and Borderlights.

## 200/400/600 Watt LED 6' Spectra Strip Linear Wash

Preliminary Specifications

*Specifications subject to change without notice.*

### Features:

- Color Mixing via Red, Green, Blue & Amber Luxeon Rebel LED's
- White Light via 3000°K high CRI Luxeon Rebel LED's for no color & tinting applications, as well as for use with standard color filters.
- Dual-Slot accessory frame holders per compartment for use with lenses, diffusing, and color media.
- Convection cooled without the use of fans
- Compatible with DMX and RDM protocols. DMX Address assignable via RDM or on-board push button display
- User selectable 8 and 16-Bit personalities for smooth fades from 0 to 100%
- Flicker-free "on camera" operation
- Preset Modes to emulate 3 and 4 Circuit traditional strip lights, as well as cell by cell control.

- Low Profile fixture suitable for uplighting and footlight applications.
- On board multi-voltage power supply
- Available Black, White, and Silver paint finishes
- Weight: Approximately 48 lbs. (21.78kg)
- ETL & cETL pending for Indoor use

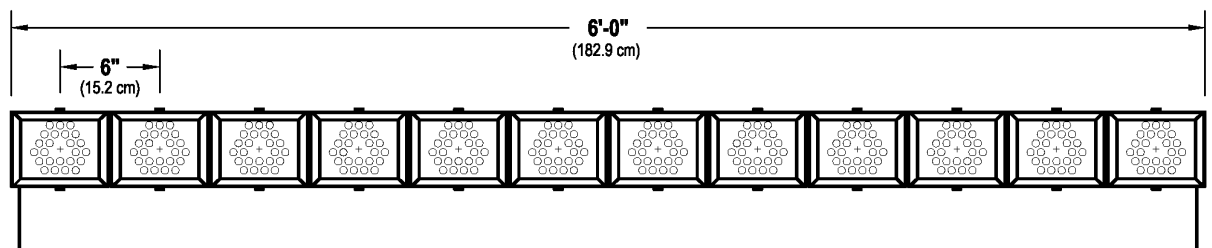
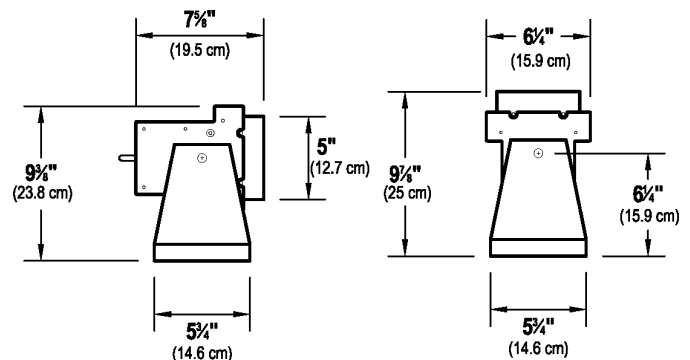

**ALTMAN**  
Lighting, Inc.

BRINGING IMAGINATION TO LIGHT 800.4.ALTMAN Fax:914.963.7304

57 Alexander Street, Yonkers, NY 10701 Tel: 914.476.7987, 212.569.7777;

## 6' Linear LED Wash Fixture

### Specifications:

#### General:

- 200/400/600w Color Mixing and/or White LED Fixture
- Available in 6' lengths with power & data pass thru
- ETL pending for indoor dry location use

#### Physical:

- Rugged extruded and sheet aluminum construction
- Corrosion-resistant materials and hardware
- Dual access slots per compartment for spread lenses & color media. Two access doors per slot for tools free accessory access from either side of luminaire
- Available in Black, White or Silver TGIC polyester, electrostatic application. Custom colors available
- Approx. 48lbs. (21.78 kg)
- Convection cooled without the use of fans. Requires free air flow around fixture.

#### Electrical:

- Multi-Voltage; 120-240 volt AC 50/60 Hz universal power input
- Neutrik® PowerCon™ input connector
- 3m power lead provided with bare ends. Factory installed connector options available.
- Requires power from a constant or switched source

#### LED:

- 50,000 hour LED life
- Up to (12) Light Engines per fixture utilizing Luxeon Rebel LED's— 50 Watts Max per light Engine at full RGBA or 3000° K White.

#### Color:

- Color Mixing Light Engines utilize a 4-color mixing system (Red, Green, Blue, and Amber)
- White Light Engines utilize 3000° K high-color rendering LEDs for crisp, clean light that blends seamlessly with conventional sources.
- White light engines can be used for basic illumination as well as tinting the output of the color mixing engines. White light engines can also be used with conventional color media.

#### Optical:

- Approximately 20° beam spread per light engine.
- Spread lenses install on a per compartment basis to change the beam spread of that compartment.
- Lenses are available as an additional accessory

#### Control:

- DMX-512A and RDM via 5-Pin XLR male & female receptacles.
- 8 or 16bit resolution selectable per light engine per fixture
- Preset configurations for cell by cell control, whole fixture control, 3-circuit strip light emulation, & 4-circuit strip light emulation.
- Virtual master channel available for all cells and modes
- Refer to operations manual for channels required for each configuration.

Part Number: SS-STRIP-*_*_*_*_*			
Model	Wattage*	Light Engines**	Color***
SS-STRIP-*_*_*_*_*	600	RGBA	BK (Black)
		RGBA+W	WH (White)
		RGBA+W+W	SL (Silver)
400		W	
		RGBA	
		RGBA+W	
200		RGBA	
		W	
		W	

Please refer to *Configuration Options* on the next page for details of available wattage & light engine configurations.

Accessories Supplied with Spectra Strip	
SS-ST-FT	Black Floor Trunions, pair
SC-36-BK	Safety Cable with Spring Clip
SS-ST-CF	Color Frame (one frame per light engine installed)

Additional Accessories	
508	Hanging Arm & Clamp, pair
SS-ST-YOKE	6' Yoke for Spectra Strip with (2) 510-HD Pipe Clamps
SS-ST-LSL	Spectra Strip Linear Spread Lens
SS-ST-BL	Spectra Strip Frosted Blending Lens
XLR-5-5	5' 5 Pin DMX Extension Cable
XLR-5-10	10' 5-Pin XLR Extension Cable
XLR-5-25	25' 5-Pin XLR Extension Cable
99-DMX-TERM	In line 5-Pin XLR 120ohm terminator
61-0265	RAD Remote Fixture Addressing Device

## Configuration Options:

The Altman Spectra Strip is available with different combinations of Color Mixing and White Light LED Engines. There are (12) Compartments per 6' Strip. Each compartment can be outfitted with a Color Mixing LED Engine, a White Light LED Engine, or a blank (no light engine).

Standard Configurations for the Spectra Strip are as follows:

### 600w/ 12 Light Engine Options:

**SS-STRIP-600-RGBA-\*\*\*\*:** Color Mixing Spectra-Strip with (12) 50W RGBA light engines.

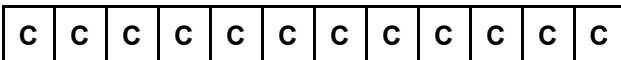

**SS-STRIP-600-RGBA+W-\*\*\*:** Color Mixing Spectra Strip with (8) 50w RGBA light engines and (4) white light engines. White light engines are used to tint the output of the color mixing system.

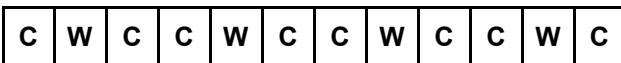

**SS-STRIP-600-RGBA+W+W-\*\*\*:** Color Mixing Spectra Strip with (4) 50w RGBA light engines and (8) white light engines. White light engines are used to tint the output of the color mixing system as well as with traditional color media.

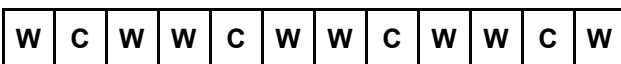

**SS-STRIP-600-W-\*\*\*:** White Light Spectra Strip with (12) RGBA Light engines. For use as general illumination and with traditional color media.

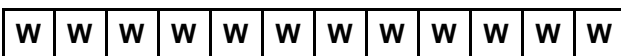

Symbol	Light Engine
C	50w RGBA Color Mixing Engine
W	50w 3000° K White Light Engine
	No Light Engine

### 400w/ 8 Light Engine Options:

**SS-STRIP-400-RGBA-\*\*\*:** Color Mixing Spectra-Strip with (8) 50W RGBA light engines.



**SS-STRIP-400-RGBA+W-\*\*\*:** Color Mixing Spectra Strip with (4) 50w RGBA light engines and (4) white light engines. White light engines are used to tint the output of the color mixing system and for general illumination.



### 200w/ 4 Light Engine Options:

**SS-STRIP-200-RGBA-\*\*\*:** Color Mixing Spectra-Strip with (4) 50W RGBA light engines. This is the basic replacement for traditional Borderlights.



**SS-STRIP-200-W-\*\*\*:** White Light Spectra Strip with (4) RGBA Light engines. For use as general illumination and with traditional color media.

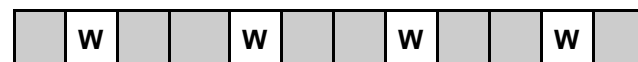

## Basic Wiring Diagram:

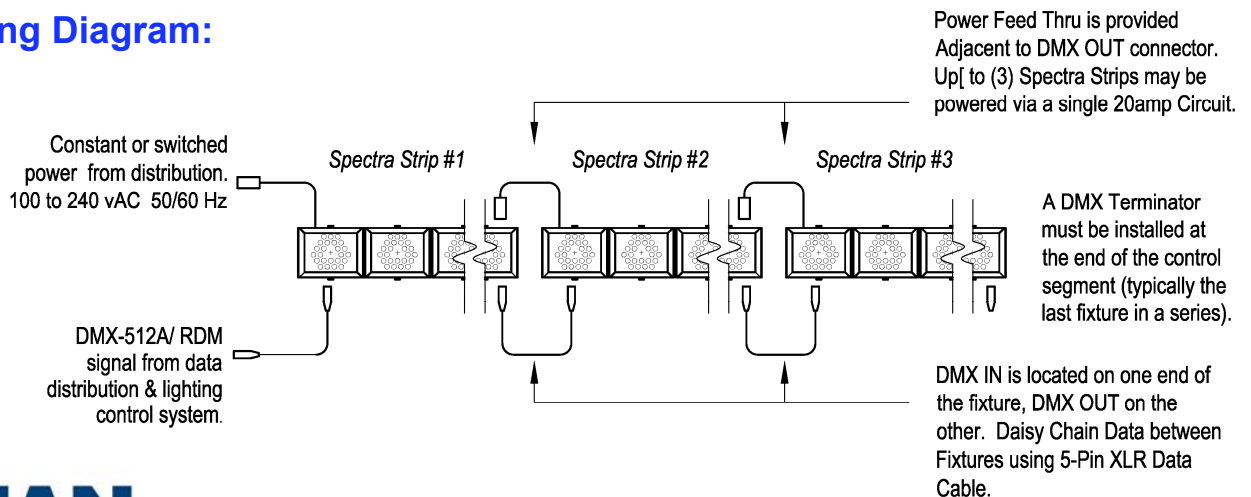



BRINGING IMAGINATION TO LIGHT 57 Alexander Street, Yonkers, NY 10701 Tel: 914.476.7987, 212.569.7777; 800.4.ALTMAN Fax:914.963.7304  
Visit our website at [www.altmanltg.com](http://www.altmanltg.com) © 2010 Altman Stage lighting Company, Inc.