



**Apollo Design Technology, Inc.**

4130 Fourier Drive  
Fort Wayne, IN 46818  
USA

PH: +01(260)497-9191  
FX: +01(260)497-9192

[www.apollodesign.net](http://www.apollodesign.net)

09-24-10



## Right Arm® - Automated Gear

© Apollo Design Technology Inc. 2007

Product covered by US patent 6,953,270

### 5-6 POWERING UP THE RIGHT ARM

When power is applied to the Right Arm® a homing sequence will occur. The Right Arm® will slowly move to its calibration point. After homing is completed, the Right Arm® will move to the home position at 0% tilt and 50% pan. The Right Arm® will wait in this position until DMX information is received.

### 5-7 SELF TEST

Setting a fixture address to 801 or 802 will run the Right Arm® in a self-test or demonstration mode where it runs through a short movement routine. 801 runs this test at full speed, 802 runs it at a slower speed.

### IMPORTANT SAFETY NOTICE!

**The Right Arm® has the potential of tilting a full 270°. Attaching accessories, such as gobo rotators, color scrollers, or gel frames, is the sole responsibility of the user. Be sure to use and approved safety cables and mounting methods to secure these devices. Be careful to install safety cables in such a way as to not inhibit the movement of the Right Arm®.**

### RIGHT ARM® REPAIRS

- All Right Arms are covered by a 12-month parts and labor warranty. The warranty covers parts and labor for 12 months and freight for 30 days after initial purchase. In case of warranty claims, please contact Apollo Design Technology, Inc. directly at 4130 Fourier Drive, Fort Wayne, IN 46818.
- Products being returned for warranty repair must display the original serial number sticker. Removal of the serial number sticker voids the product's limited warranty.
- Despite the care taken for the compilation of this book, Apollo Design Technology, Inc. cannot be held responsible for any damages resulting from errors that may appear in this book. All efforts have been made to provide the most accurate, up-to-date instructions and illustrations possible.
- Need assistance? Call Apollo at 800-288-4626 for details.

**Keep this information handy if requiring assistance.**

Serial Number: \_\_\_\_\_

Date Purchased: \_\_\_\_\_

Purchased From: \_\_\_\_\_

## 5-2 CHANNEL ASSIGNMENTS

Option	DMX Channels
8 Bit	1 Pan, 2 Tilt
8 Bit + Speed	1 Pan, 2 Tilt, 3 Speed
16 Bit + Speed	1 Pan Coarse, 2 Pan Fine, 3 Tilt Coarse, 4 Tilt Fine, 5 Speed

## FORMAT OF SPEED CHANNEL

Modes that have a speed channel (Modes 3-8) use the following format:

- 0 Full speed (desk control)
- 1 – 49% Fast speed to slow speed
- 50 – 70% Slowest speed
- 71 – 89% Reset if pan and tilt are at 0 and DMX values are held stationary for 3 seconds or more
- 90 – 100% Full speed (desk control)

## 5-3 DATA PASS THROUGH

There are two XLR 5 pin data connectors. One is male for data input. The other is a female for daisy chaining other DMX fixtures. The data is a straight pass through and is not buffered or isolated. If the power is removed from the Right Arm® other DMX devices will not be affected.

## 5-4 LOSS OF DMX

If the DMX data to the Right Arm® ceases, the unit will hold the last position. When the DMX signal is restored normal operation will resume.

## 5-5 ACCESSORY OUTPUTS

There are two accessory output ports to connect devices to such as Smart Color® Scrollers or Smart Move® Rotators.

The total power available for these accessories must not exceed 40 watts. The voltage output is 24 volts DC. The connectors are XLR 4 pin females. The pin out for the connectors is:

- |                  |                     |
|------------------|---------------------|
| Pin 1 DC common  | Pin 3 DMX Data +    |
| Pin 2 DMX Data - | Pin 4 DC 24 volts + |

When utilizing the accessory ports be sure to route and secure cabling in such a way as to not impede the movement of the Right Arm®.

## TABLE OF CONTENTS:

	PAGE NO.
<b>SECTION 1 - INTRODUCTION</b>	
1-1 General information	4
1-2 Compatible fixtures	4
<b>SECTION 2 - SPECIFICATIONS</b>	
2-1 Dimensions, Weight and Performance	5
2-2 Compliance	6
2-3 Electrical	6
2-4 Protocol	6
2-5 Motors	6
<b>SECTION 3 - SAFETY</b>	
3-1 Safety	6
<b>SECTION 4 - INSTALLATION AND SET-UP</b>	
4-1 Unpack and Inspect	7
4-2 Installing Connectors	7
4-3 Hanging the Right Arm®	8
4-4 Attaching a Fixture to the Right Arm®	9
4-5 Balancing the Fixture	10-11
4-6 Data Cable	13
<b>SECTION 5 - OPERATION</b>	
5-1 Mode Switch Settings	13
5-2 Channel Assignments and Format of Speed Channel	14
5-3 Data Pass Through	14
5-4 Loss Of DMX	14
5-5 Accessory Outputs	14
5-6 Powering Up The Right Arm®	15
Repairs And Warranty	15

## SECTION 1 - INTRODUCTION

**BE SURE TO READ AND UNDERSTAND EVERYTHING IN THIS MANUAL BEFORE USING THE RIGHT ARM!**

### 1-1 GENERAL INFORMATION

The Right Arm® is designed to accommodate a wide variety of small to medium sized lighting fixtures. The Right Arm® has a patented balance system that eliminates the need for counter balances. The Right Arm® is controlled from any DMX512 console and can be operated in 8-bit or 16-bit resolution. Large stepper motors and high gear ratio drive provides silent and accurate operation.

### 1-2 COMPATIBLE FIXTURES

The Right Arm® can accommodate fixtures of approximately the size shown below:

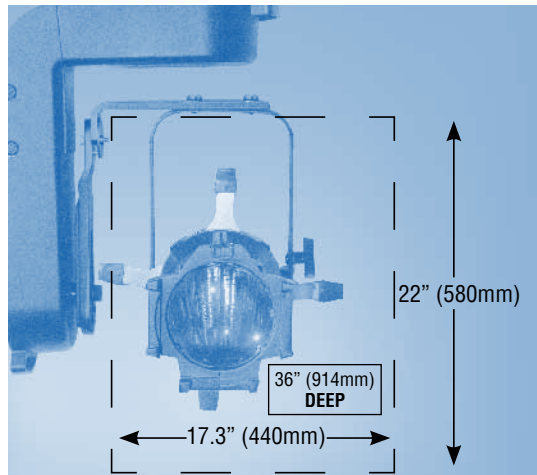

Maximum Fixture Dimensions

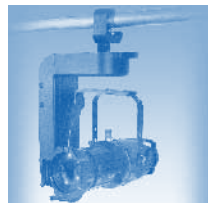

Ellipsoidals & Fresnels



PARs



Video Cameras



Projectors

### 4-6 DATA CABLE

Data cable must be twisted pairs, 120Ω, shielded E1A485 cable (Belden 9829, 9842 or equivalent), minimum 22 AWG.

Recommended Maximum cable length: 1000'

Maximum DMX receiving devices recommended per single line: 32

The last DMX device on the line must be terminated with a 120Ω resistor.

Data in connector: XLR 5 pin male

Data out connector: XLR 5 pin female

## SECTION 5 - OPERATION

### 5-1 MODE SWITCH SETTINGS

With the mode switch set from 0 through 8, the address switch should be set to the DMX address desired.

Mode switch settings allow the user to choose different ranges of pan and tilt, 8 or 16 bit resolution, and whether or not a channel to control speed is required.

Mode	Switch Setting
200° Pan and Tilt, 8 Bit	0
120° Pan and Tilt, 8 Bit	1
90° Pan and Tilt, 8 Bit	2
200° Pan and Tilt, 8 Bit + Speed	3
120° Pan and Tilt, 8 Bit + Speed	4
90° Pan and Tilt, 8 Bit + Speed	5
340° Pan, 270° Tilt, 16 Bit + Speed	6
200° Pan and Tilt, 16 Bit + Speed	7
120° Pan and Tilt, 16 Bit + Speed	8

Rotate the tilt arm back until the fixture points straight ahead. If the fixture holds this position, the balance is correct. If not, the angle of the arm needs to be modified. See the drawings below of the tilt arm angle. This angle should only require adjustment on a fixture that is front heavy such as a long throw ellipsoidal or a fixture with a color changer.

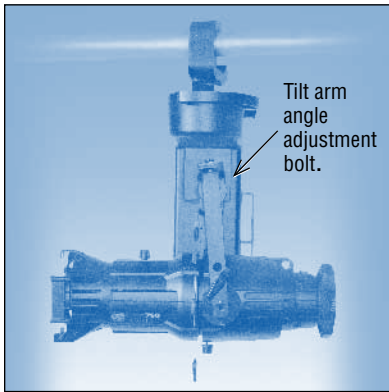

Tilt arm angle set at normal position.

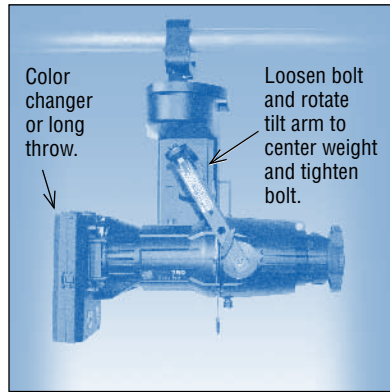

Tilt arm angle set to accommodate a fixture that is front heavy.

Adjust this angle until the fixture holds its position. The balance should be confirmed in all positions.

Proper balancing of the Right Arm® assures accurate position during operation.

Extreme fixture imbalances created by 5° or 10° lenses, will require Right Arm® accessory part number RIGHTARM - 20200.

### IMPORTANT SAFETY NOTICE!

**The Right Arm® has the potential of tilting a full 270°. Attaching accessories, such as gobo rotators, color scrollers, or gel frames, is the sole responsibility of the user. Be sure to use approved safety cables and mounting methods to secure these devices. Be careful to install safety cables in such a way as to not inhibit the movement of the Right Arm®.**

## SECTION 2 - SPECIFICATIONS

### 2-1 DIMENSIONS, WEIGHT AND PERFORMANCE

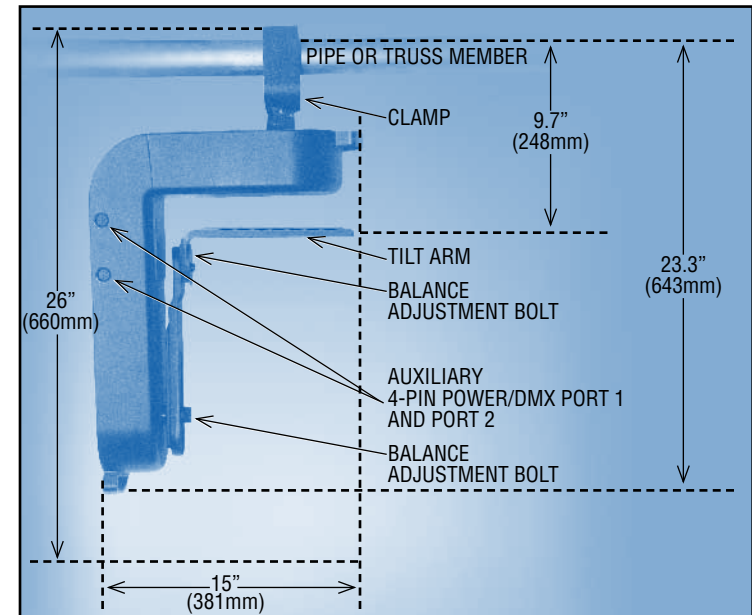

#### Overall Dimensions and Key Components

Height:	26" (660.4 mm) with clamp
Height, hang below pipe:	23.3" (591.8 mm)
Width:	15" (381 mm)
Depth:	7" (177.8 mm)
Torque, pan:	5 foot-pounds average
Torque, tilt:	10 foot-pounds average
Pan Range:	340°
Pan Speed:	180° in 6 seconds
Tilt Range:	270°
Tilt Speed:	180° in 6 seconds
Right Arm™ Weight:	28 lb (12.7kg) without fixture
Shipping Weight:	34lb (15.4 kg) without fixture
Capacity:	40 lb (18.4 kg)

## 2-2 COMPLIANCE

This fixture is designed to comply with UL STD 73, Eighth Edition Motor Operated Appliances. CE rated

## 2-3 ELECTRICAL

Operating voltage:	100-240 VAC $\pm$ 5%
	50/60 Hz (auto select)
Fixture power cord rating:	15 amps, 250 volts Maximum
Accessory port voltage:	24 volts DC
Accessory port wattage:	40 watts maximum
Current required for Right Arm® alone:	.5 amps
Power required for Right Arm®:	50 watts

## 2-4 PROTOCOL

USITT DMX512	
Start code:	(00h)
Maximum load:	32 fixtures per DMX link
Maximum length of DMX link:	1000 feet
Required control channels:	5 (16-bit) or 3 (8-bit)
Termination:	120 $\Omega$

## 2-5 MOTORS

High torque stepper motor	
Step Angle:	1.8°, 1/256 microstep

## SECTION 3 - SAFETY

A moving light is a dangerous piece of equipment. It is for professional use only.

**Attaching accessories, such as gobo rotators, color scrollers, or gel frames, is the sole responsibility of the user. Use approved safety cables and mounting methods to secure these devices.**

If the power cable is damaged it must be replaced by the manufacturer, the service agent or a similarly qualified person in order to avoid a hazard.

Follow all safety procedures that apply to the lighting fixture to be attached to the Right Arm®, per the manufacturer's instructions.

The Right Arm® is designed for use only with fixtures up to 40 lb. Always ground (earth) the Right Arm®.

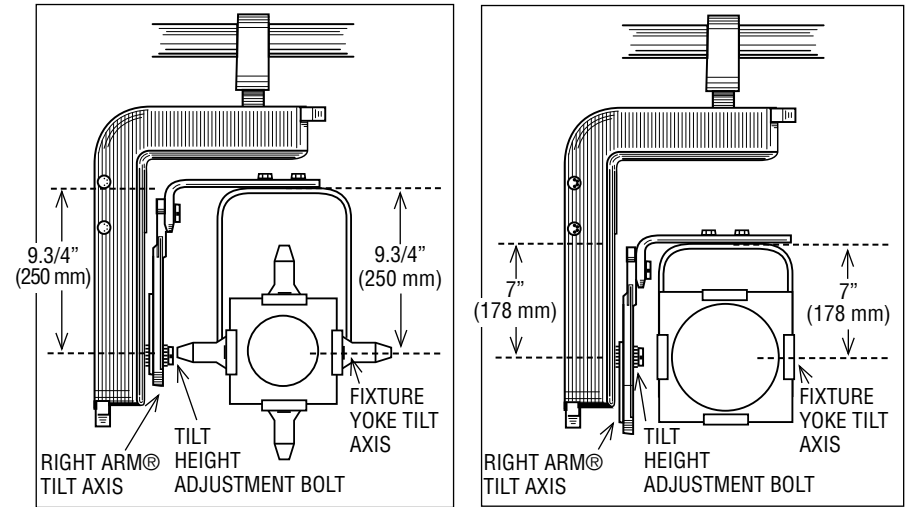

ETC Source Four Ellipsoidal  
ETC Yoke Measures 9 3/4"  
Adjust Tilt Arm To 9 3/4"

ETC S4 PAR  
ETC Yoke Height 7"  
Adjust Tilt Arm To 7"

With the power off, check to see if the height adjustment is correct by observing if the fixture holds its position after rotating it to point down as shown below.

If the fixture holds its position proceed to the next step, if not change the height of the arm and recheck.

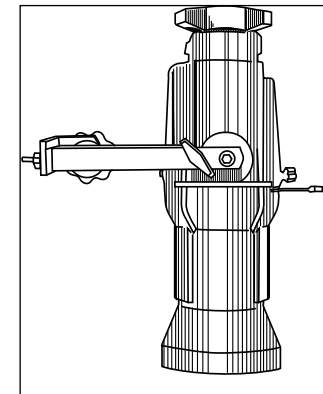

Rotate To Face Down

5. Connect the lamp power cable to the wire that exits at the tilt shaft.
6. Secure the cable so that it does not interfere with the tilt motion.

#### 4-5 BALANCING THE FIXTURE

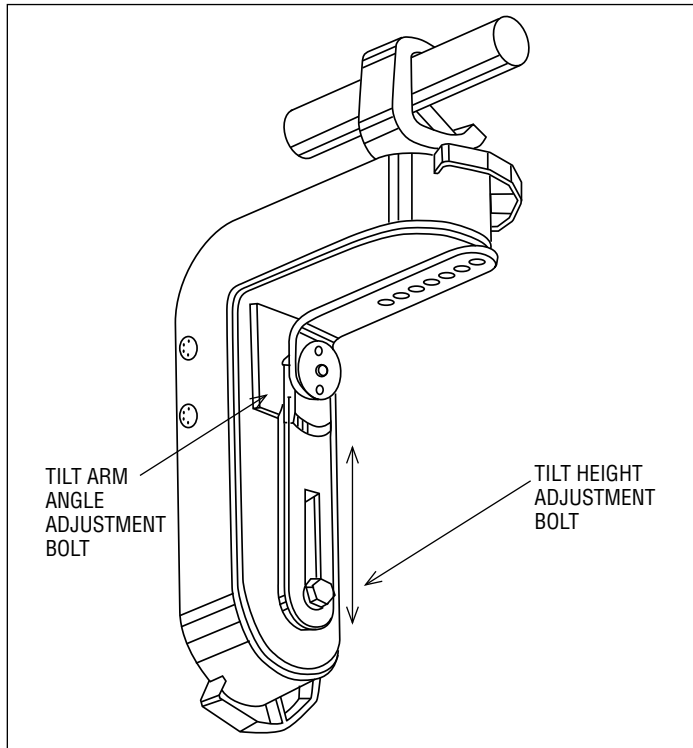

The tilt arm height and the tilt arm angle provide two adjustment points for balance.

The tilt arm height is adjusted by the tilt height adjustment bolt. Loosen this bolt to adjust for different height fixtures. The initial adjustment should be set so the tilt axis of the fixture is at the same height as the tilt bolt. See examples on the following page:

Always suspend the Right Arm® using the clamp provided. Hang only on secured truss, pipe, or other structures. The Right Arm® is not designed to hang vertically. Always use approved safety cables when hanging the Right Arm®. Always disconnect the Right Arm® from AC power before service. Do not expose Right Arm® to dripping or splashing. Objects filled with liquid shall not be placed on the unit. Do not put flammable materials on or near the Right Arm®.

### SECTION 4 - INSTALLATION AND SET-UP

#### 4-1 UNPACK AND INSPECT

Verify that the Right Arm® has arrived complete and undamaged. The shipping container should contain the following items:

- |                              |  |
|------------------------------|--|
| 1. Right Arm®.               | 4. Bolt for pipe clamp metric M16x30 hex head. Includes flat washer and lock washer. |
| 2. Right Arm® user's Manual. | 5. Safety cables (2)   |
| 3. Pipe clamp.               |  |

#### 4-2 INSTALLING CONNECTORS

The Right Arm® comes with two cables for control and two for power. DMX control in and pass through are provided using five pin XLR type connectors. One power cable is marked "do no dim" and is used to provide power to the Right Arm® electronics. This cable *must* be plugged in to a non-dimmed electrical source between 90 volts and 250 volts AC. Plugging this cable in to a dimmed electrical source could damage the Right Arm®.



The second power cable enters the top of the Right Arm® and passes through the Right Arm® exiting at the tilt shaft. This cable is used to power devices attached to the Right Arm®. This cable has 16 gauge conductors and can be plugged into a dimmed or non-dimmed source to power fixtures up to 15 amps.



When installing connectors use the brown wire for hot, the blue wire for neutral and the green/yellow wire for ground. Observe proper grounding on all three power connectors. Both male connectors are used as the disconnect device and shall remain readily accessible after the installation of the Right Arm® has been completed.

#### 4-3 HANGING THE RIGHT ARM®



The Right Arm® must be securely attached with the clamp provided. Position the power box to fit inside of the dotted lines on the Right Arm® label. Position the clamp with the pipe bolt facing towards the Right Arm® rail handles.

The Right Arm® can be hung vertically with the clamp on top or bottom. The Right Arm® cannot be hung horizontally with the clamp on either side.

Be sure to tighten the bolt that fastens the clamp to the Right Arm®. The Right Arm® must use the provided safety cable to prevent the unit from falling in the event that the hanging clamps or brackets fail.



The provided safety must pass through the hole on the pan shaft and also around the pipe or truss. When attaching the safety cable, keep in mind the range of motion necessary for the Right Arm® to operate properly and adjust the length and/or placement of the cable accordingly.

#### 4-4 ATTACHING A FIXTURE TO THE RIGHT ARM®

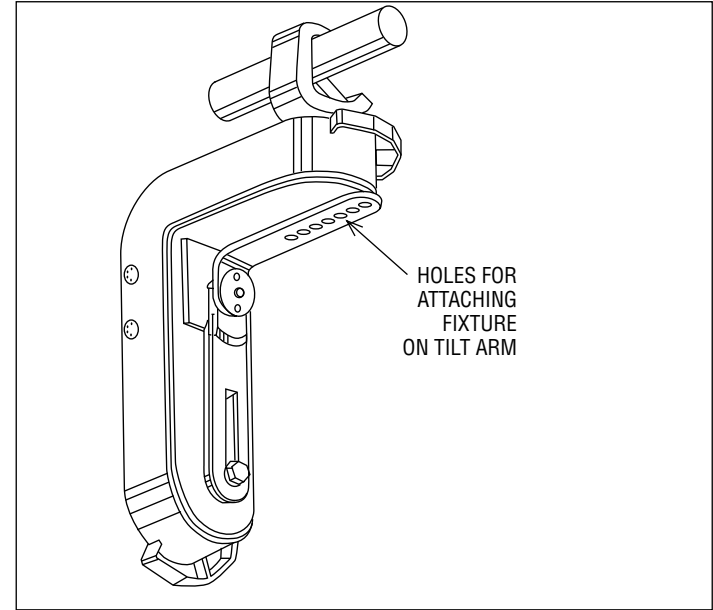

1. Remove any C-clamps or other hanging brackets from the fixture to be installed in the Right Arm®.
2. Bolt the fixture's yoke to the top of the tilt arm. There are seven holes in the tilt arm. Use the hole that is closest to the inside corner of the Right Arm® and allows operation of all parts of the lighting fixtures. Use lock nuts or lock washers (not provided). For single hole use 1/2" bolt or double hole use 3/8" bolt.
3. Attach the provided safety cable. This safety should be connected to the fixture according to the fixture manufacturer's instructions.



4. The safety must also pass through the hole provided on the tilt shaft. When attaching the safety cable, keep in mind the range of motion necessary for the Right Arm® to operate properly and adjust the length and/or placement of the cable accordingly.