

VocoPro[®]

THE SINGER'S ULTIMATE CHOICE[™]

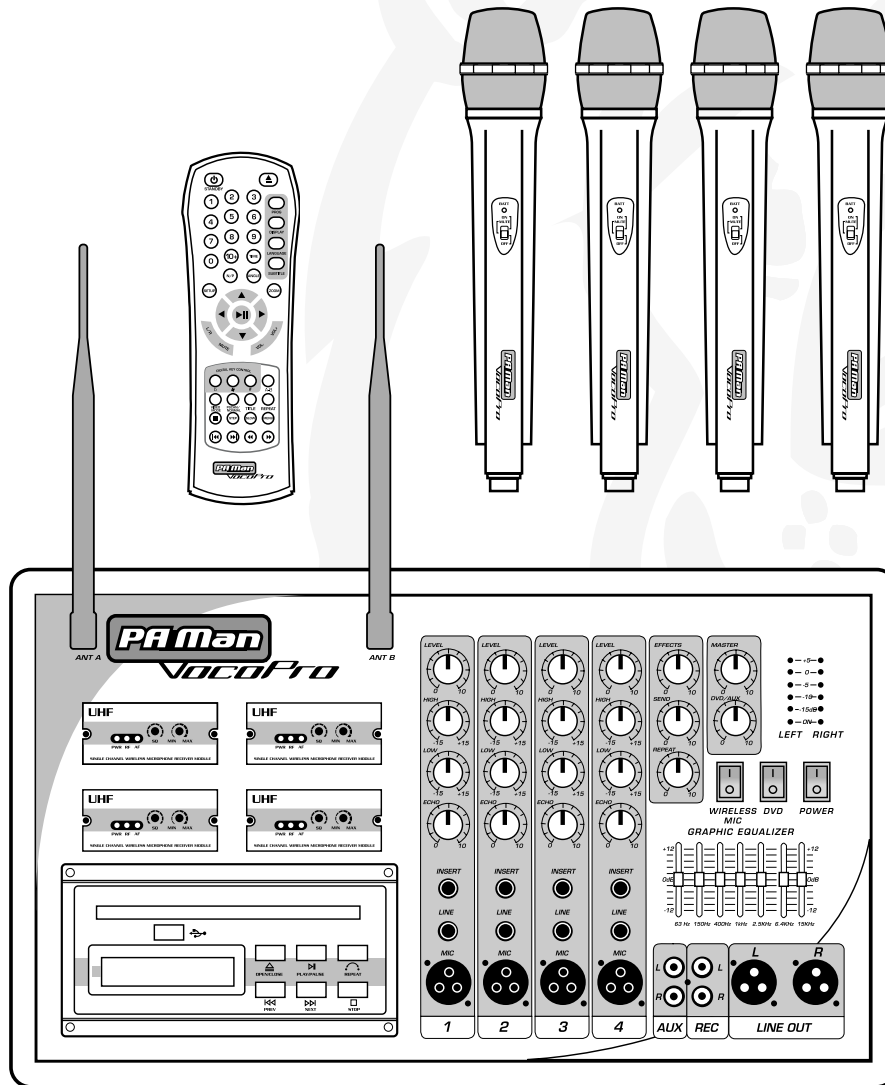

o w n e r ' s m a n u a l

PA-MAN

All-In-One Four-Channel Wireless P.A. System

Table of Contents

FCC Information	3
Listening for a Lifetime.....	4
Safety Instructions.....	5
Welcome	6
Features and Specifications	7
Before Getting Started	8
Getting Started	9
Getting Connected	
Connecting Speakers	10
Connecting a TV or Monitor.....	11
Connecting External Devices	12
Descriptions and Functions	
Front Panel.....	13
Rear Panel	14
UHF Modules	14
Disc/USB player	15
MIC Channel controls	16
Microphone	17
Remote Control	18-19
General Operations.....	20-23
Media File Operations	24
Removing Modules	25
Setting up Preferences	26-28
Troubleshooting	29-30

FCC INFORMATION (U.S.A.)

1. IMPORTANT NOTICE: DO NOT MODIFY THIS

UNIT!: This product, when installed as indicated in the instructions contained in this manual, meets FCC requirements. Modifications not expressly approved by Vocopro may void your authority, granted by the FCC, to use this product.

2. IMPORTANT: When connecting this product to accessories and/or another product use only high quality shielded cables. Cable(s) supplied with this product **MUST** be used. Follow all installation instructions. Failure to follow instructions could void your FCC authorization to use this product in the U.S.A.

3. NOTE: This product has been tested and found to comply with the requirements listed in FCC Regulations, Part 15 for Class "B" digital devices. Compliance with these requirements provides a reasonable level of assurances that your use of this product in a residential environment will not result in harmful interference with other electronic devices. This equipment generates/uses radio frequencies and, if not installed and used according to the instructions found in the owner's manual, may cause interference harmful to the operation of other electronic devices. Compliance with FCC regulations does not guarantee that interference will not occur in all installations. If this product is found to be the source of interference, which can be determined by turning the unit "Off" and "On", please try to eliminate the problem by using one of the following measures:

Relocate either this product or the device that is being affected by the interference.

Use power outlets that are on different branch (circuit breaker or fuse) circuits or install AC line filter(s).

In the case of radio or TV interference, relocate/reorient the antenna. If the antenna lead-in is 300-ohm ribbon lead, change the lead-in to coaxial type cable.

If these corrective measures do not produce satisfactory results, please contact your local retailer authorized to distribute Vocopro products. If you can not locate the appropriate retailer, please contact Vocopro, 1728 Curtiss Court, La Verne, CA 91750.

CAUTION:

READ THIS BEFORE OPERATING YOUR UNIT

1. To ensure the finest performance, please read this manual carefully. Keep it in a safe place for future reference.
2. Install your unit in a cool, dry, clean place - away from windows, heat sources, and too much vibration, dust, moisture or cold. Avoid sources of hum (transformers, v motors). To prevent fire or electrical shock, do not expose to rain and water.
3. Do not operate the unit upside-down.
4. Never open the cabinet. If a foreign object drops into the set, contact your dealer.
5. Place the unit in a location with adequate air circulation. Do not interfere with its proper ventilation; this will cause the internal temperature to rise and may result in a failure.
6. Do not use force on switches, knobs or cords. When moving the unit, first turn the unit off. Then gently disconnect the power plug and the cords connecting to other equipment. Never pull the cord itself.
7. Do not attempt to clean the unit with chemical solvents: this might damage the finish. Use a clean, dry cloth.
8. Be sure to read the "Troubleshooting" section on common operating errors before concluding that your unit is faulty.
9. This unit consumes a fair amount of power even when the power switch is turned off. We recommend that you unplug the power cord from the wall outlet if the unit is not going to be used for a long time. This will save electricity and help prevent fire hazards. To disconnect the cord, pull it out by grasping the plug. Never pull the cord itself.
10. To prevent lightning damage, pull out the power cord and remove the antenna cable during an electrical storm.
11. The general digital signals may interfere with other equipment such as tuners or receivers. Move the system farther away from such equipment if interference is observed.

NOTE:

Please check the copyright laws in your country before recording from records, compact discs, radio, etc. Recording of copyrighted material may infringe copyright laws.

CAUTION

The apparatus is not disconnected from the AC power source so long as it is connected to the wall outlet, even if the apparatus itself is turned off. To fully insure that the apparatus is indeed fully void of residual power, leave unit disconnected from the AC outlet for at least fifteen seconds.

Voltage Selector (General Model Only)

Be sure to position the voltage selector to match the voltage of your local power lines before installing the unit.

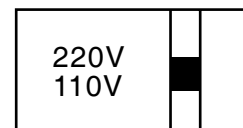

Listening for a lifetime

Selecting fine audio equipment such as the unit you've just purchased is only the start of your musical enjoyment. Now it's time to consider how you can maximize the fun and excitement your equipment offers. VocoPro and the Electronic Industries Association's Consumer Electronics Group want you to get the most out of your equipment by playing it at a safe level. One that lets the sound come through loud and clear without annoying blaring or distortion and, most importantly, without affecting your sensitive hearing.

Sound can be deceiving. Over time your hearing "comfort level" adapts to a higher volume of sound. So what sounds "normal" can actually be loud and harmful to your hearing. Guard against this by setting your equipment at a safe level BEFORE your hearing adapts.

To establish a safe level:

- Start your volume control at a low setting.
- Slowly increase the sound until you can hear it comfortably and clearly, and without distortion.

Once you have established a comfortable sound level:

- Set the dial and leave it there.
- Pay attention to the different levels in various recordings.

Taking a minute to do this now will help to prevent hearing damage or loss in the future. After all, we want you listening for a lifetime.

Used wisely, your new sound equipment will provide a lifetime of fun and enjoyment. Since hearing damage from loud noise is often undetectable until it is too late, this manufacturer and the Electronic Industries Association's Consumer Electronics Group recommend you avoid prolonged exposure to excessive noise. This list of sound levels is included for your protection.

Some common decibel ranges:

Level	Example
30	Quiet library, Soft whispers
40	Living room, Refrigerator, Bedroom away from traffic
50	Light traffic, Normal Conversation
60	Air Conditioner at 20 ft., Sewing machine
70	Vacuum cleaner, Hair dryer, Noisy Restaurant
80	Average city traffic, Garbage disposals, Alarm clock at 2 ft.

The following noises can be dangerous under constant exposure:

Level	Example
90	Subway, Motorcycle, Truck traffic, Lawn Mower
100	Garbage truck, Chainsaw, Pneumatics drill
120	Rock band concert in front of speakers
140	Gunshot blast, Jet plane
180	Rocket launching pad

Safety Instructions



CAUTION
RISK OF SHOCK



CAUTION: To reduce the risk of electric shock, do not remove cover (or back). No user-serviceable parts inside. Only refer servicing to qualified service personnel.

Explanation of Graphical Symbols



The lightning flash & arrowhead symbol, within an equilateral triangle, is intended to alert you to the presence of danger.



The exclamation point within an equilateral triangle is intended to alert you to the presence of important operating and servicing instructions.

WARNING

To reduce the risk of fire or electric shock, do not expose this unit to rain or moisture.

1. Read Instructions - All the safety and operating instructions should be read before the appliance is operated.

2. Retain Instructions - The safety and operating instructions should be retained for future reference.

3. Heed Warnings - All warnings on the appliance and in the operating instructions should be adhered to.

4. Follow Instructions - All operating and use instructions should be followed.

5. Attachments - Do not use attachments not recommended by the product manufacturer as they may cause hazards.

6. Water and Moisture - Do not use this unit near water. For example, near a bathtub or in a wet basement and the like.

7. Carts and Stands - The appliance should be used only with a cart or stand that is recommended by the manufacturer.

7 A. An appliance and cart combination should be moved with care. Quick stops, excessive force, and uneven surfaces may cause an overturn.



8. Ventilation - The appliance should be situated so its location does not interfere with its proper ventilation. For example, the appliance should not be situated on a bed, sofa, rug, or similar surface that may block the ventilation slots.

9. Heat - The appliance should be situated away from heat sources such as radiators, heat registers, stoves, or other appliances (including amplifiers) that produce heat.

10. Power Sources - The appliance should be connected to a power supply only of the type described in the operating instructions or as marked on the appliance.

11. Grounding or Polarization - Precautions should be taken so that the grounding or polarization means of an appliance is not defeated.

12. Power-Cord Protection - Power-supply cords should be routed so that they are not likely to be walked on or pinched by items placed upon or against them, paying particular attention to cords at plugs, convenience receptacles, and the point where they exit from the appliance.

13. Cleaning - Unplug this unit from the wall outlet before cleaning. Do not use liquid cleaners or aerosol cleaners. Use a damp cloth for cleaning.

14. Power lines - An outdoor antenna should be located away from power lines.

15. Nonuse Periods - The power cord of the appliance should be unplugged from the outlet when left unused for a long period of time.

16. Object and Liquid Entry - Care should be taken so that objects do not fall and liquids are not spilled into the enclosure through openings.

17. Damage Requiring Service - The appliance should be serviced by qualified service personnel when:

- A. The power supply cord or plug has been damaged; or
- B. Objects have fallen into the appliance; or
- C. The appliance has been exposed to rain; or
- D. The appliance does not appear to operate normally or exhibits a marked change in performance; or
- E. The appliance has been dropped, or the enclosure damaged.

18. Servicing - The user should not attempt to service the appliance beyond that described in the operating instructions. All other servicing should be referred to qualified service personnel.

Note:

To CATV system installer's (U.S.A.): This reminder is provided to call the CATV system installer's attention to Article 820-40 of the NEC that provides guidelines for proper grounding and, in particular, specifies that the cable ground shall be connected as close to the point of cable entry as practical.



Welcome

And thank you for purchasing the **PA-MAN** from VocoPro, your ultimate choice in Karaoke entertainment! With years of experience in the music entertainment business, VocoPro is a leading manufacturer of Karaoke equipment, and has been providing patrons of bars, churches, schools, clubs and individual consumers the opportunity to sound like a star with full-scale club models, in-home systems and mobile units. All our products offer solid performance and sound reliability, and to reinforce our commitment to customer satisfaction, we have customer service and technical support professionals ready to assist you with your needs. We have provided some contact information for you below.

VocoPro

1728 Curtiss Court
La Verne, CA 91750
Toll Free: 800-678-5348
TEL: 909-593-8893
FAX: 909-593-8890

VocoPro Company Email Directory

Customer Service & General Information

info@vocopro.com

Tech Support

techsupport@vocopro.com

Remember Our Website

Be sure to visit the VocoPro website **www.vocopro.com** for the latest information on new products, packages and promos. And while you're there don't forget to check out our Club VocoPro for Karaoke news and events, chat rooms, club directories and even a KJ Service directory!

We look forward to hearing you sound like a PRO, with VocoPro, the singer's ultimate choice.

FOR YOUR RECORDS

Please record the model number and serial number below, for easy reference, in case of loss or theft. These numbers are located on the rear panel of the unit. Space is also provided for other relevant information

Model Number

Serial Number

Date of Purchase

Place of Purchase

Features and Specifications

- Four Channel Mixing and Effect Control
- Master EQ, Effect and Volume Controls
- Four Handheld Wireless Mics
- Four Independent Field-Replaceable Wireless Modules
- Built-in Removable DVD/CD/CD+G Player with USB Reader
- LED Level Indicators
- Conserve Power with Individual Component Power Switches
- All-In-One Mobility with Carrying Handles

Specifications

Maximal Power Output: **2 x 100W/8ohm**

Total Harmonic Distortion: **<0.1%**

Frequency Response: **50Hz/20KHz±3dB**

Power & Voltage: **AC 110V 60Hz / AC 220V 50Hz**

Built-in Wireless Receiver: **UHF 740MHz-790MHz**

Weight: **33lb, (15kg)**

Dimension: **17.5 x 11.8 x 10.2 in, (44.5 x 30 x 26 cm)**

Before Getting Started

Thank you for purchasing the PA-MAN system. The PA-MAN will provide years of reliability and high quality entertainment for you if used properly. Please read this manual carefully before using your PA-MAN to ensure best performance.

Unpacking the PA-MAN:

Carefully remove the PA-MAN from its carton. It is recommended that you store the original packaging materials in case you need to ship this equipment for any reason.

Be sure you have the following parts and components included with your PA-MAN:

ITEMS:

- 1 PA-MAN
- 2 Antennas
- 1 RCA Video Cable
- 1 Remote Control
- 8 AA Batteries
- 2 AAA Batteries
- 1 AC Power Cable
- 1 Warranty Card

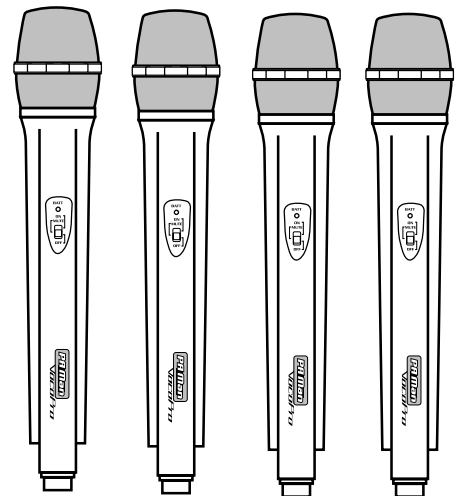
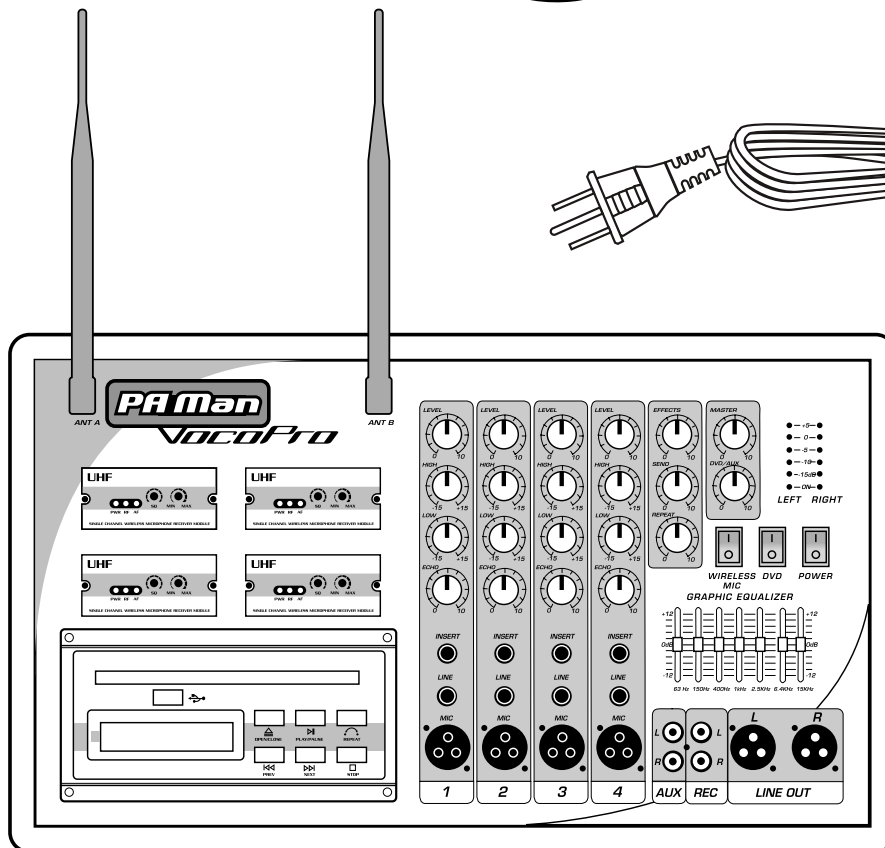
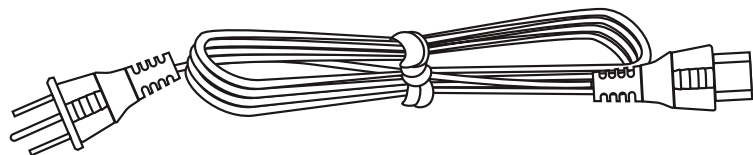
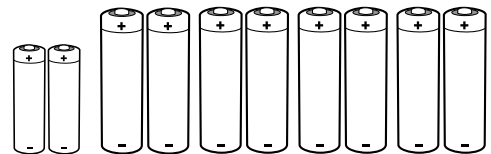
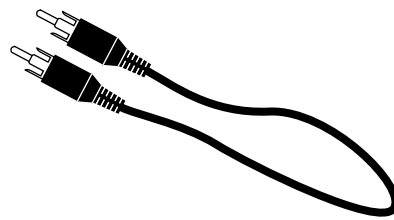
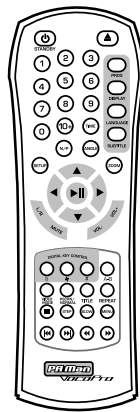

Getting Started

About the Remote Control

- The area between the remote control and the main unit must be clear of large obstacles.
- Do not expose the remote control sensor to strong lighting, especially an inverter type fluorescent lamp as this may cause the remote control to not function properly.

Installing Batteries in the Remote Control

1. Turn the remote control over and slide the battery compartment cover off.
2. Insert the AAA batteries, positioning them according to the polarity (+, -) markings on the inside of the battery compartment.
3. Close the battery compartment cover.

Battery Replacement

If you find that the distance between the remote control and the main unit must be shorter in order to use the remote control, this means that the batteries are low and must be changed. Replace both batteries with new ones.

Battery Notes:

- Use AAA batteries.
- Be sure the polarities (+, -) are correct. (See the illustration inside the battery compartment).
- Remove the batteries when not using the remote control for an extended period of time.
- If batteries leak, dispose of them immediately. Avoid skin, clothing and any other contact with the leaked material. Clean the battery compartment thoroughly before installing new batteries.
- Do not mix old and new batteries.
- Do not mix alkaline, standard (carbon-zinc) with rechargeable (nickel-cadmium) batteries.

Connecting the Antennas

Connect each of the two included antennas to the connections labeled ANT A and ANT B on the front panel of the PA-MAN and turn each clockwise to lock.

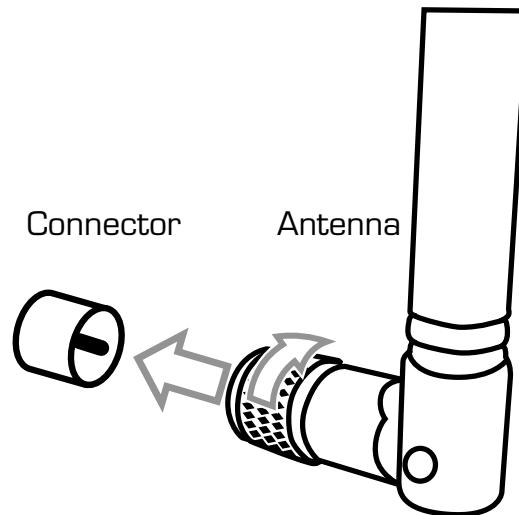

Connecting the Power Cable

Plug the supplied AC power cable into the AC inlet after all other connections are complete and then plug the AC power cable to an AC wall outlet.

CAUTION

Use the supplied AC cable. Do not use other AC power cables as doing so may result in fire hazard or electrical shock.

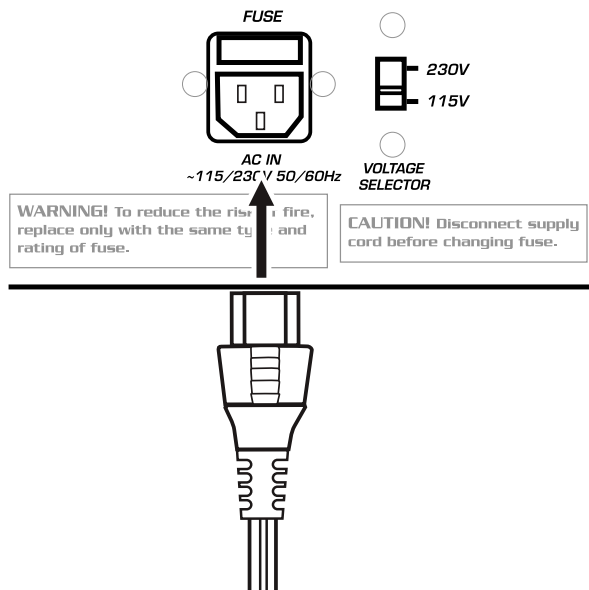

Getting Connected

Connecting Speakers

The 1/4" output jacks are located on the rear panel. Use these to connect speakers with a 1/4" connection.*

- Before connecting the speakers, make sure that the PA-MAN is disconnected from the power source.
- Connect the left speaker to the left output (L), connect the right speaker to the right output (R).

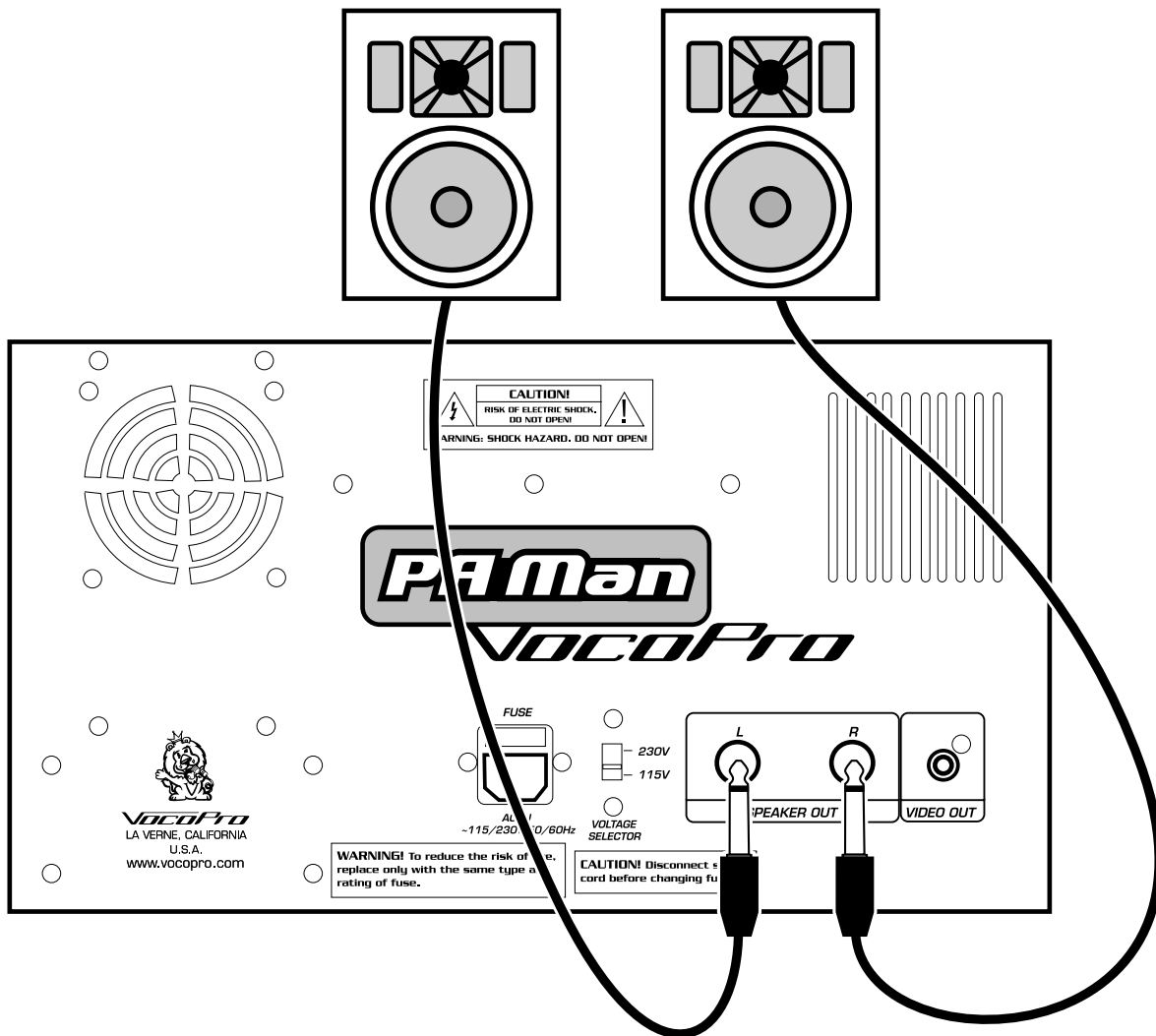

*If your speakers have connectors other than 1/4", and you are unsure which cable type to obtain, please consult the speaker's user manual or call the VocoPro tech-support department at 800-678-5348 Mon. - Fri 9 am - 4 pm PST.

Getting Connected, cont.

Connecting a TV or Monitor to the PA-MAN

The PA-MAN has a VIDEO OUTPUT jack which sends video from the disc player to TVs and other video monitor devices.

- Connect an RCA style video cable (included) from the VIDEO OUTPUT on the PA-MAN to the VIDEO INPUT jack on your TV or other monitor. While some models automatically switch when a video signal is detected, you may need to manually switch your TV to video mode. On most TVs, the INPUT jack is labeled A/V, AUX or VIDEO IN.

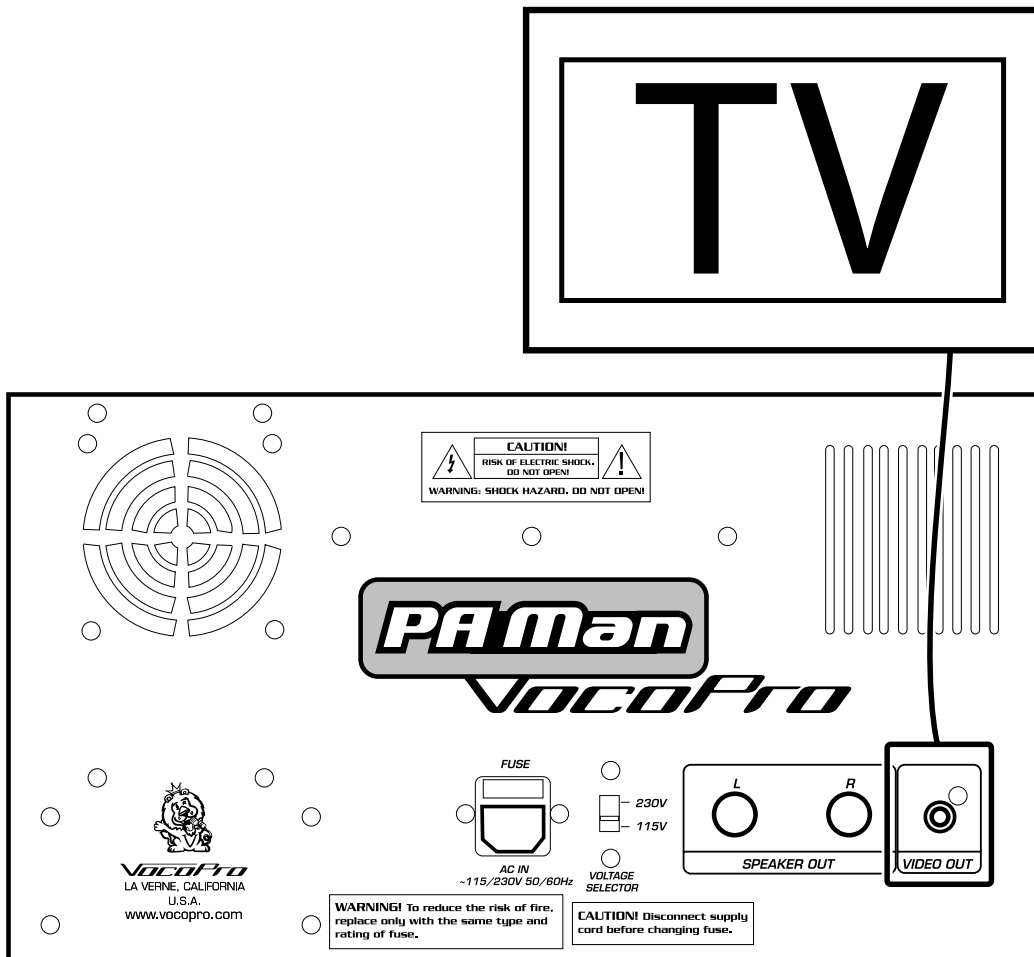

Getting Connected, cont.

Connecting External Devices

Use the provided connections on each of the four channels to connect external devices such as microphones, effects processors and other audio devices.

- **Insert** - Connect an external effects processor to each channel with this 1/4" input. To ensure that your effects processor will properly function with the PA-MAN's INSERT connection, use a cable with a 1/4" stereo TRS (tip ring sleeve) connector.
- **Line** - Connect any microphone or instrument device with a 1/4" mono connector to this line level connection.
- **XLR Balanced Microphone Input** - Connect a balanced XLR microphone cable here to add an additional mic input to the channel.

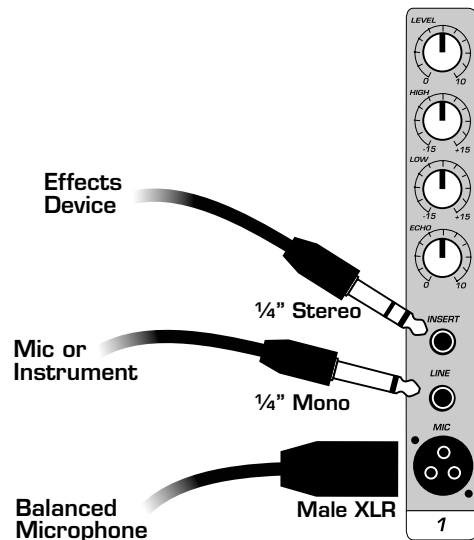

Connecting an External Effects Device

Connect your effects device to the INSERT connection with the proper cables for your device. The illustration below is an example of how an external effects device may be connected to the PA-MAN. It is suggested that you consult the user manual for your individual effects device for information on making this connection and use of the proper cable connector.

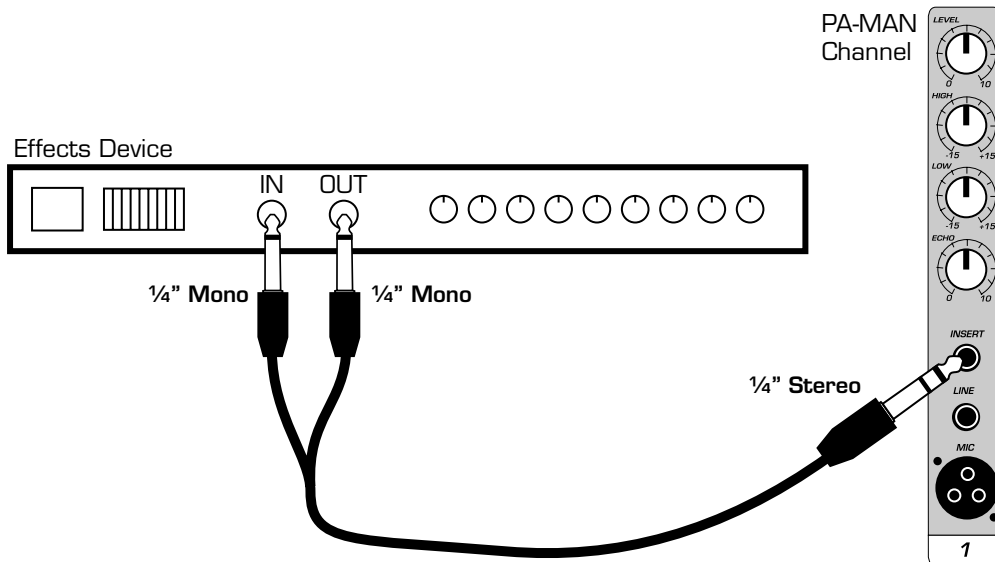

Descriptions and Functions

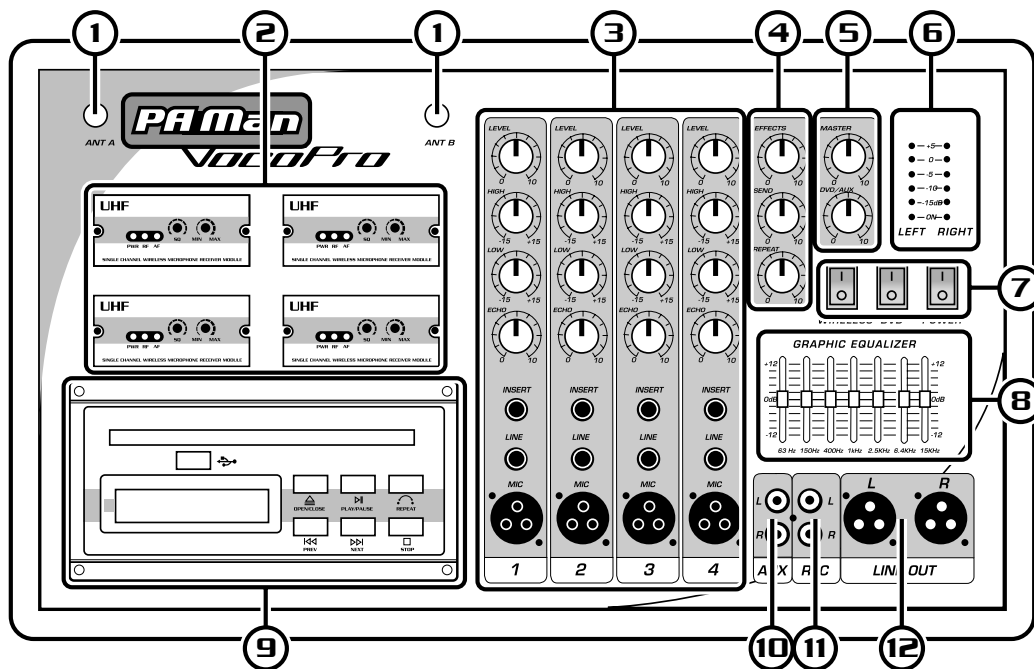

Front Panel

1. **TNC Antenna Connection** - Connect the included antennas to both terminals by twisting clockwise. To remove the antennas, unscrew the connectors counter-clockwise.
2. **UHF Modules** - See page 14.
3. **Microphone Channel Input and Effect Controls**- See page 17 for more detail.
4. **Master Effects Controls** - Control the level of the effects on microphone output with EFFECTS knob. Turn clockwise to increase effects, counter-clockwise to decrease.
 - Delay Knob** - This control adjusts the length of time for each ECHO interval, or REPEAT. Rotating the DELAY control clockwise will increase the DELAY, creating the effect of more "space."
 - Repeat Knob** - This control adjusts the number of ECHO repeats applied to the signal until the effect decays, or fades out.
5. **Master Level Controls** - Control the volume output of all audio with the MASTER knob, adjust the output of the DISC PLAYER or connected AUX player with the DVD/AUX knob. Turn clockwise to increase volume, counter-clockwise to decrease.
6. **LED Level Indicator** - This indicator will allow you to monitor the decibal levels of the audio output, making it easier to avoid peak distortion.
7. **Individual Component Power Swtiches** - Use these switches to power off the DISC PLAYER or UHF MODULES when they are not in use. The POWER button controls power for the entire unit.
8. **Graphic Equalizer Control** - This GRAPHIC EQ is used to BOOST and/or CUT particular frequencies from SOURCE MUSIC output. Each slide fader process' a particular frequency range indicated by the number above it. Frequencies from 63Hz - 150Hz constitute the very low to low range. Frequencies from 150Hz to 2.5kHz are the mid-range and frequencies from 2.5kHz to 15kHz make up the high to very high range. To adjust slide the fader up to boost the frequency presence and down to cut the frequency presence.
9. **Multi-Format Disc/USB Player** - See page 15.
10. **AUX Input** - Connect an additional media player or any output device to the RCA audio inputs.
11. **REC Output** - Output the audio signal from the PA-MAN for monitoring or recording purposes.
12. **XLR L/R Line Outputs** - Output the PA-MAN audio through stereo XLR connections to an input device.

Note: Output level controlled by the master volume control.

Descriptions and Functions, cont.

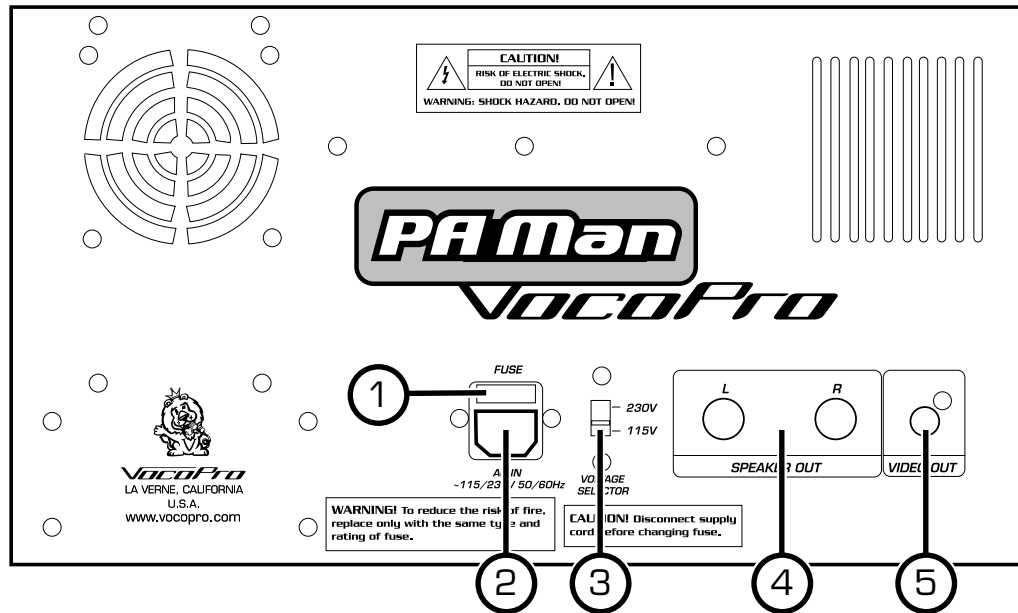

Rear Panel

1. **Fuse** - This plastic cover is the housing for the PA-MAN's fuse. When replacing the fuse, only use the same type and rating.
2. **Power Input** - Connect the power cord (included) here.
3. **Voltage Selector Switch** - This switch is used to select the voltage setting according to country. For use in the U.S. the voltage selector should be set to 115V. In Europe, set to 230V.
4. **¼" Speaker Outputs** - Use these speaker left and right outputs to connect speakers.
5. **RCA Video Output** - Connect an RCA video cable from this connection to your TV or input device's video input.

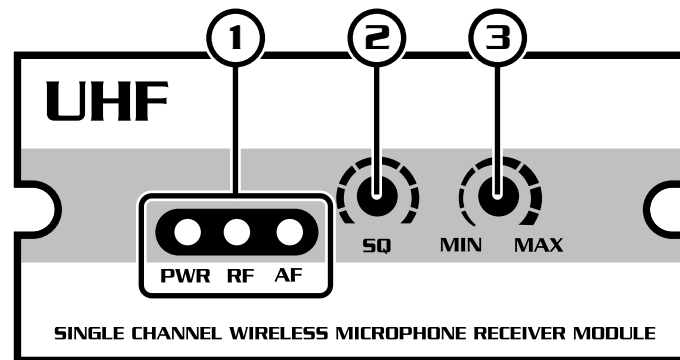

UHF Modules

1. **UHF Module indicator LEDs-**
 - POWER (LED) - Indicates whether the UHF-Module is ON or OFF. When it is lit, the power is ON.
 - RF (LED) - Lights when the corresponding microphone is powered on.
 - AF (LED) - Lights when AF signals are received from the microphone channels.
2. **Squelch** - Manual controls for controlling each microphone's signal strength for best performance. Turn clockwise to increase SQUELCH control and turn counter-clockwise to decrease SQUELCH application.
3. **Level Control** - Adjusts the individual VOLUME of the receiver's 4 microphone channels.

Descriptions and Functions, cont.

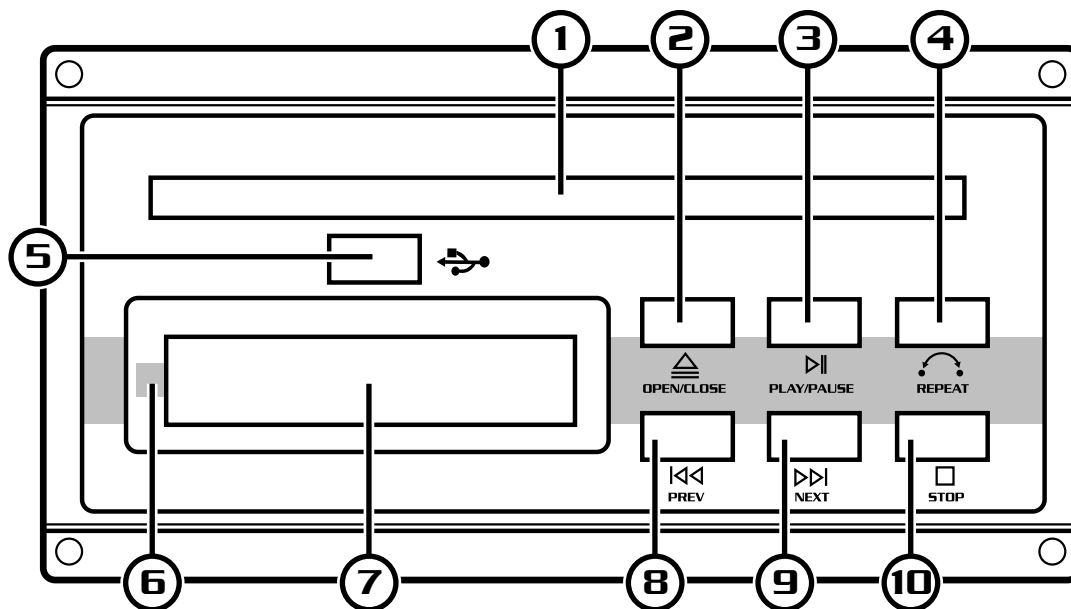

Multi-Format Disc/USB Player

- 1. Disc Tray** - Press the "OPEN/CLOSE" button (See #2 on diagram) to open the CD/CD+G tray. Carefully set your DVD/CD/CD+G disc onto the tray and press the OPEN/CLOSE button again to close tray. Never push or force tray closed manually.
- 2. Open/Close Button (▲)** - Opens and closes the disc tray
- 3. Play/Pause Button (▶||)** - Plays a disc that is stopped or paused and pauses a disc that is playing.
- 4. Repeat Button (↺)** - Cycles through the available repeat options: CD/CD+G: Repeat One, Repeat All, Repeat Off. DVD: Repeat Chapter, Repeat Title, Repeat Off.
- 5. USB Port** - Connect a thumbdrive loaded with tracks and videos to this port. Use the onscreen navigation menu to select files for playback.
- 6. Remote Sensor** - When operating the PA-MAN with the REMOTE CONTROL, direct the REMOTE towards this SENSOR within 23 feet. Maintain a line of sight between REMOTE and REMOTE SENSOR clear of obstacles to prevent signal deflection.
- 7. LCD Display** - Displays track, playback and setting information.
- 8. Previous Button (◀◀)** - Press PREV to jump to the previous track.
- 9. Next Button (▶▶)** - Press NEXT to jump to the next track.
- 10. Stop Button (■)** - Stops a disc that is playing.

Descriptions and Functions, cont.

Microphone Channel Input and Effect Control

1. **Level** - Adjust the volume output of the microphone channel.
2. **High** - Adjust the high end of your microphone output, adding treble to the audio.
3. **Low** - Adjust the low end of your microphone output, adding bass to the audio.
4. **Echo** - This controls the overall level for the ECHO effect on all three MIC INPUTS. This effect applies slight delayed repetition(s) to the vocals providing for a rich, layered vocal sound. Rotate clockwise to increase the amount of ECHO effect applied to the signal, and counter-clockwise to decrease.
5. **1/4" Insert Effects Loop Output/Input** - Connect an external effects processor to each channel with this 1/4" input. To ensure that your effects processor will properly function with the PA-MAN's INSERT connection, use a cable with a 1/4" stereo TRS (tip ring sleeve) connector.
6. **1/4" Line Input** - Connect any microphone or instrument device with a 1/4" mono connector to this line level connection.
7. **XLR Microphone Input** - Connect an XLR microphone cable here to add an additional mic input to the channel.

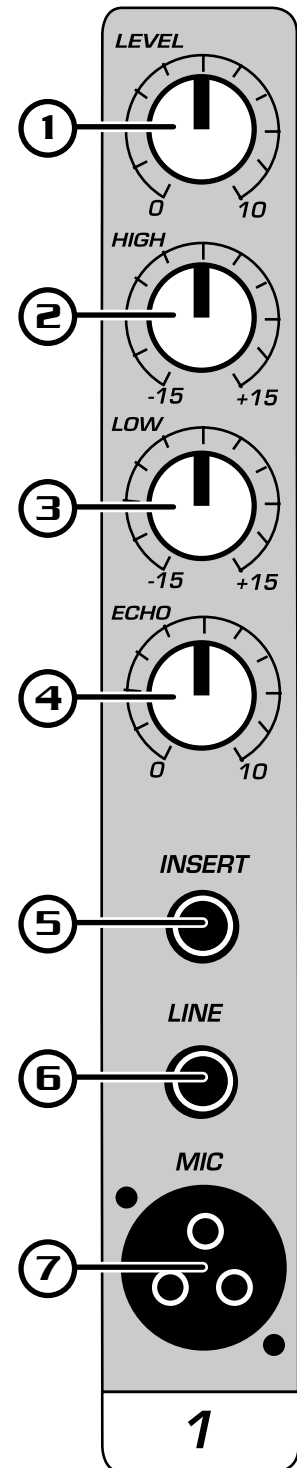

Descriptions and Functions, cont.

Microphone

1. **LED**- This will blink on when microphone power is switched on, it will remain lit if the battery is weak and needs replacement.
2. **On**- Turn the microphone power on by moving the switch to the highest position.
3. **Mute**- Mute the audio output from the microphone by moving the switch to this position in the center.
4. **Off**- Turn microphone power off by moving the switch to the lowest position.

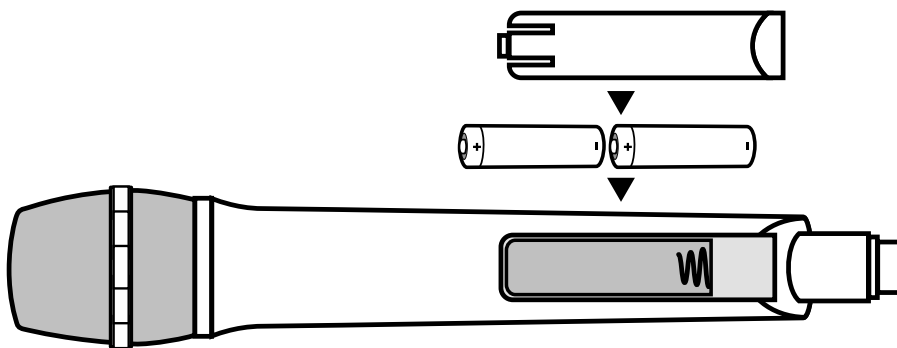
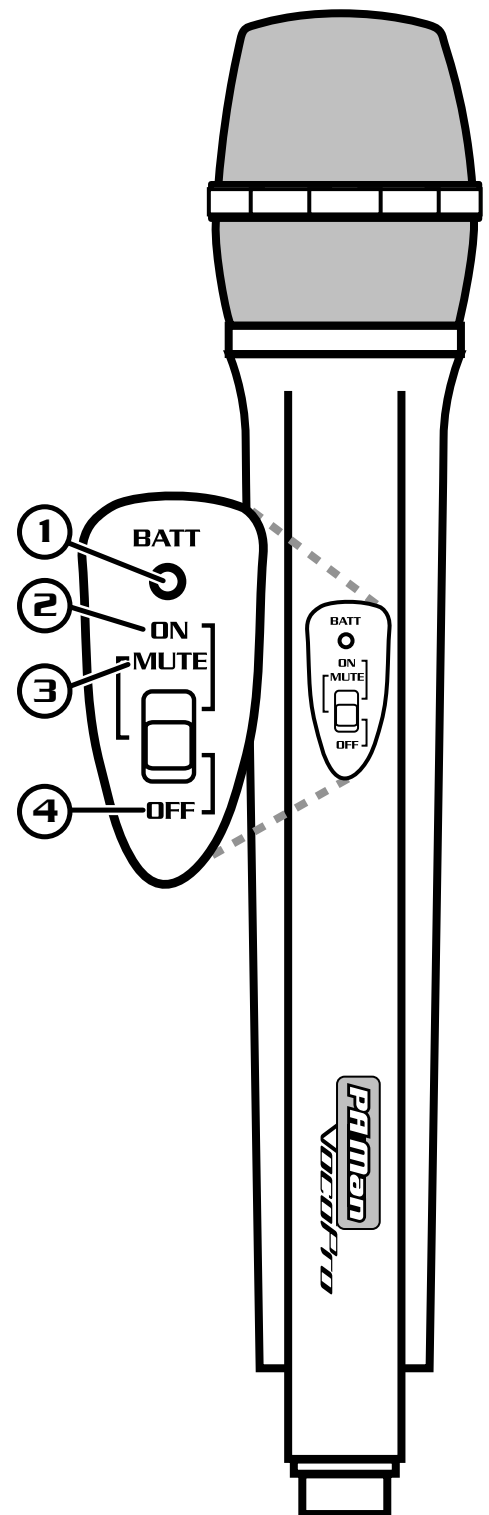

Handheld Microphone Battery Installation

1. To remove the lid, press down on the tab and slide the lid down toward the bottom of the mic.
2. Insert two fresh 1.5-volt AA alkaline batteries. Make sure the batteries are inserted in the right direction according to polarity (+/-).
3. Close the BATTERY COMPARTMENT lid.

Descriptions and Functions, cont.

Remote Control

1. **Standby** - Put the PA-MAN DISC PLAYER in standby mode.
2. **Direct Access** - For use whenever number input is necessary. i.e. Jumping directly to tracks/chapters, etc.
3. **Time** - Use the arrow key and direct access keys to jump to a track or specific time in the current track from this display. See the "Jumping..." instructions in the General Operations section of this manual on page 20.
4. **N/P** - Switches between PAL and NTSC video modes. To change video modes, press the P/N button until desired mode is selected.
5. **Setup** - Accesses the Setup Menu. See the Setting Up references section in this manual for detailed instructions on using the Setup Menu.
6. **Play/Pause** (▶||) - Plays a disc that is stopped or paused and pauses a disc that is playing.
7. **L/R** - Cycles through the different multiplex CD+G output modes for canceling the vocals. This feature only works on multiplex CD+G discs. Mono L - No Vocals, Mono R - Vocals
8. **Mute** - Mutes all disc audio.
9. **Digital Key Control** - Adjusts the musical key of music to fit the singer's vocal range.
 - b - Lowers the musical key
 - ♯ - Resets the music to the original or 'natural' key
 - # - Raises the musical key

NOTE: Digital Key Control changes the key of music but will not affect the microphone vocals.
10. **PScan/Normal** - This button changes video output mode.

NOTE: The PA-MAN only has one output option, so this feature is not enabled on the PA-MAN.
11. **Video Mode** - To change the video display mode press the VIDEO button until desired mode is selected. Choose MEMORY to enable the video mode adjustments made in the VIDEO SETUP page in the SETUP MENU. See Setting Up Preferences for more information.
12. **Stop** (■) - Stops the disc or track that is playing.
13. **Step** - For viewing one frame at a time on video discs.
14. **Prev/Next** (◀▶) - Press PREV ◀ to jump to the previous track. Press NEXT ▶ to jump to the next track.

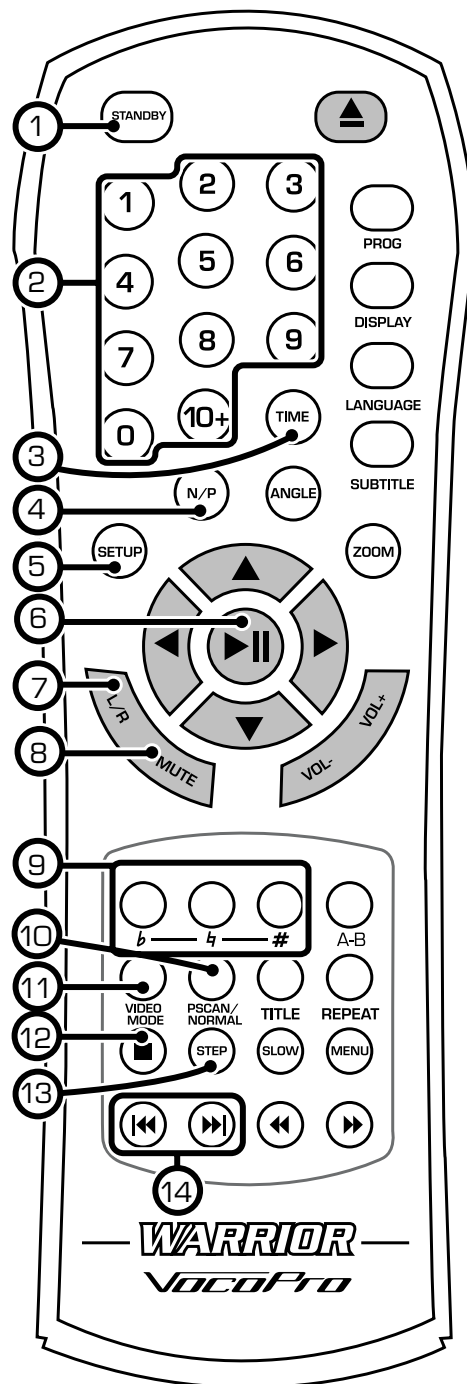

Descriptions and Functions, cont.

Remote Control, cont.

- 15. **Open/Close** (▲) - Opens and closes the disc tray.
- 16. **Program** - Opens the Program Menu which lets you program a custom playlist order of up to 16 tracks or DVD chapters. Check the "Programming..." directions in the General Operations of this manual on page 21.
- 17. **Display** - Cycles through available disc time info and displays it on the TV/video monitor.
- 18. **Language** - Cycles between the available audio languages on DVDs with multiple languages available.
- 19. **Subtitle** - Turns on subtitles for DVDs with subtitles available
- 20. **Angle** - For viewing multiple angles on a DVD with multiple angles available.
- 21. **Zoom** - For zooming in or out on the picture on DVDs, JPEGs and VCDs.
- 22. **Arrow Keys** - For navigating through on-screen menus.
- 23. **Volume** - Adjusts the disc player volume.
- 24. **A-B** - For setting a section on a disc for continuous looping. Press again to cancel. Does not function on CD+G discs.
- 25. **Title** - Accesses the title screen on a DVD.
- 26. **Repeat** - Cycles through the available repeat options: CD/CD+G: Repeat One, Repeat All, Repeat Off. DVD: Repeat Chapter, Repeat Title, Repeat Off.
- 27. **Menu** - Accesses the main menu on DVDs and other discs with main menus.
- 28. **Slow** - Cycles through available slow-motion speeds on a DVD.
- 29. **Search** (◀▶) - For scanning through a track or chapter on a DVD. Does not function on CD+G discs.

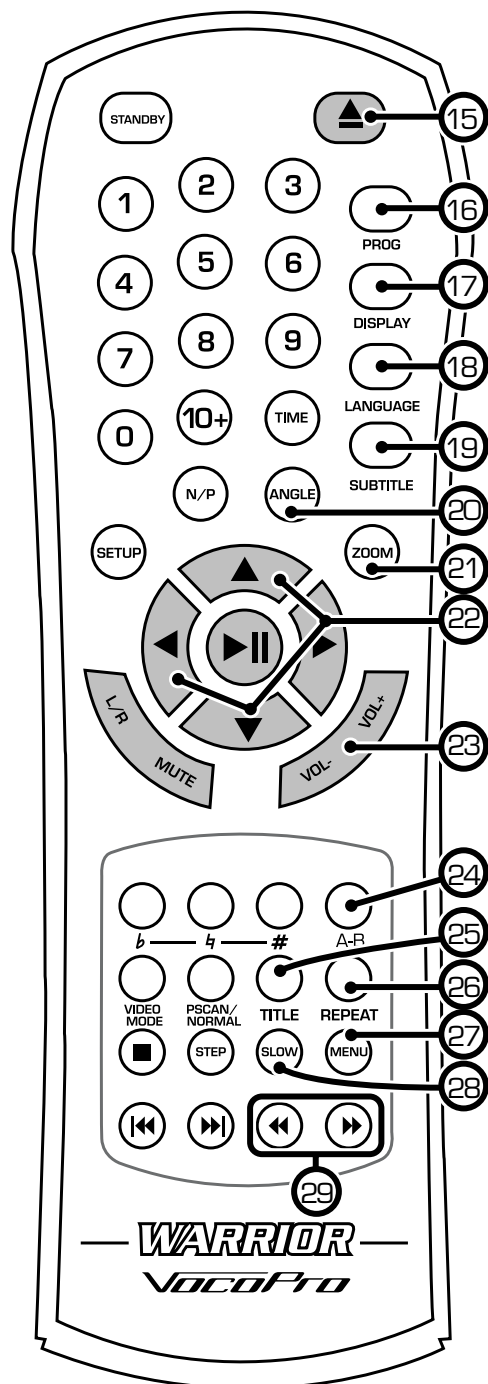

General Operations

Performing Karaoke

The PA-MAN provides microphone support, playback of CD+G discs and vocal adjustments to allow you to create Karaoke performances of your favorite songs. Follow these steps to ensure that your Karaoke performance is the best it can be.

1. Power on your wireless microphones or connect wired microphone(s) to the input(s) on the front of the PA-MAN.
2. Adjust the individual microphone settings for each channel with the LEVEL, HIGH, LOW and ECHO knobs. Each voice is different and these knobs will allow you to customize the performance.
3. Begin music playback of your CD+G or video file with the DISC PLAYER, and use the DVD/AUX volume knob and the LEVEL knobs to match the volume of the audio with the volume of your microphone vocals to make sure you and your music can be heard loud and clear.
4. If you feel that your voice pitch does not match the music perfectly, use the DIGITAL KEY CONTROL on the remote control to adjust the sharpness or flatness of the music.
5. Feel free to adjust any of these knobs further to make your sound even better. After time you will know what settings are optimal for your individual sound.

Scanning through Tracks

1. Use the ►► ◀◀ buttons on the remote control to scan through CD tracks
2. The ►► button scans forwards through the current track and the ◀◀ backwards through the current track

Adjusting the Disc Music Volume

1. Use the VOL + and VOL - buttons on the remote control to adjust the volume
2. The VOL + button raises the volume and the VOL - button lowers it

Using Direct Track Access

The Direct Track Access buttons are the number buttons on the remote control. These allow you to jump directly to a track or chapter (DVD) by entering its number.

example

To jump directly to track 9:

1. Press the 9 button
2. Press PLAY
3. Track 9 will begin playing

Jumping to a Specific Time on a Disc (CD, VCD and DVD only)

1. Press the TIME button on the remote control
2. Press the left arrow key to move to the TIME
3. Enter the specific time you would like to jump to.
4. Press PLAY
5. The disc will play at that time

General Operations

Jumping to a Specific Time on a Disc (CD, VCD and DVD only), continued...

example

To jump directly to 1:45

1. Press TIME on the remote control
2. Press the LEFT ARROW button
2. Press 0, 0, 0, 1, 4, then 5
3. Press PLAY on the remote control
4. The disc will begin playing at 1:45 minutes in the disc

Programming a Custom Track Order

The PA-MAN allows you to create a custom playlist of up to 16 tracks using the PROGRAM button on the remote control.

1. If there is a disc in the PA-MAN, make sure it is stopped
2. Press the PROGRAM button on the remote control to access the Program menu. The Program menu will appear on the TV screen
3. Enter a track number using the number buttons on the remote control
4. Press the RIGHT ARROW on the remote control to enter that track into the playlist and to jump to the next playlist slot
5. Continue this until your playlist is complete

example (on next page)

To create a playlist in the following order:

1. Track 14
2. Track 7
3. Track 3
4. Track 1

1. Press the PROGRAM button to enter Program mode
2. Press 14 and then ENTER
3. Press 7 and then ENTER
4. Press 3 and then ENTER
5. Press 1 and then ENTER
6. Move to the PLAY selection on the menu and press PLAY on the remote to begin playing in this order
7. Press STOP twice to exit the programmed playlist

Clearing tracks in Program Mode

Select the CLEAR selection on the PROGRAM menu and press the PLAY button on the remote control to erase the programmed tracks.

Using Digital Key Control

Digital Key Control allows you to change the musical key of disc music to fit any singer's vocal range. The Digital Key Control buttons are located on the remote control. Note that the music will be increasingly distorted with each step away from the natural key.

b - Lowers the musical key

4 (remote control only) - Resets the musical key back to the original or natural key

- Raises the musical key

General Operations

Setting Repeat Options

Press the REPEAT button on the remote control to cycle through the available Repeat options

- REPEAT 1: Repeats the same song continuously
- REP ALL: Repeats the entire disc after it has played through
- REPEAT DIR: Repeat a directory of files when playing media files on a drive or CD
- REPEAT OFF: All Repeat options are off
- CHAPTER REPEAT (DVD only): Repeats the current chapter on a DVD disc
- TITLE REPEAT (DVD only): Repeats the current title on a DVD disc

Switching Between PAL and NTSC Video Modes

The PA-MAN is defaulted to NTSC. Use the N/P button on the remote control to switch between PAL and NTSC.

1. If there is a disc in the PA-MAN make, sure it is stopped
2. Press the N/P button on the remote control
3. Press ENTER on the remote control. The video mode will change

PAL: Europe and Asia

NTSC: North America

Looping a Section of Disc using the A-B Button

1. Press the A-B button on the remote control to set the starting point of the loop
2. Press the A-B button again to set the ending point of the loop and to begin the loop
3. Press the A-B button a third time to cancel the loop and resume normal playback

Playing One Frame at a Time with the Step Function

The Step function allows you to view one frame at a time on DVDs and VCDs.

NOTE: The Step function does not work on CD+Gs

1. Press the STEP button to enter Step mode and pause the current frame
2. Press it again to jump to the next frame
3. Press PLAY to resume normal playback

Playing Forwards and Reverse in Slow Motion

You can play a disc forwards or reverse at 1/2, 1/4 and 1/8 the normal speed

1. Press the SLOW button on the remote control to cycle through the Slow Motion options
2. Press the PLAY button to return to normal playback

Slow Motion options:

- SF 1/2X - Forwards at 1/2 the normal speed
- SF 1/4X - Forwards at 1/4 the normal speed
- SF 1/8X - Forwards at 1/8 the normal speed
- SF 1/2X - Reverse at 1/2 the normal speed
- SF 1/4X - Reverse at 1/4 the normal speed
- SF 1/8X - Reverse at 1/8 the normal speed

General Operations

DVD Operations

Accessing the DVD Menu

Use the MENU button on the remote control to access the main menu on a DVD. Use the arrow buttons on the remote control to navigate through the main menu and the ENTER button to make selections.

Accessing the Title Screen

Each section on a DVD such as the movie, special features, etc. has its own title screen. Use the TITLE button on the remote control to access the title screen for the current section.

Turning on Subtitles

Use the SUBTITLE button on the remote control to cycle through the available subtitle languages on a DVD.

NOTE: The available subtitles vary from each DVD and some may not have any at all.

Changing the Angle View

Use the ANGLE button on the remote control to view multiple angles on a DVD with multiple angles available.

NOTE: Not all discs have multiple angles available.

Accessing Additional Dubbed Languages

Some DVDs have multiple languages dubbed over the original language for speakers of other languages. Use the AUDIO button on the remote control to cycle through these languages on DVDs with multiple languages available.

Media File Operations

MP3 Disc Playback

Load an MP3 disc.

The disc will automatically load and display the MP3 window. It may take up to 20 seconds for an MP3 disc to be read depending on the complexity of the file structure. Use the arrow keys on the remote to navigate through the window. Press the ENTER button to make selections.

USB File Playback

MP3/Photo/Video

Insert a USB thumb-drive into the USB connection on the front of the disc player. Make sure there is no disc in the disc tray. The menu will appear upon connection or press PLAY to access the menu. Select the corresponding icon in the lower right corner to view MP3, Photo (JPEG) or Video (MPEG, AVI) to view the list of each file type. Scroll through each list with the ARROW buttons and press the PLAY button to make a selection.

Music Icon - Display and playback your MP3 audio files

- Use the ARROW buttons to select a track and press enter to begin playback.
- Use the disc control buttons to control playback.

Photo Icon - Display and review your JPG images.

- Use the right ARROW to select a file, or press play on any file to begin slideshow. Smaller thumbnail preview images will appear in the left pane.
- Use the PREV/NEXT ◀▶ buttons on the front panel or the remote to skip from one image to another.
- Use the ARROW buttons on the remote to rotate the image and the ZOOM button to zoom in and out.
- Press STOP to return to the menu.

Video Icon - Display and playback your AVI, MPEG.

- Use the disc control buttons to control playback.
- Press STOP to return to the menu.

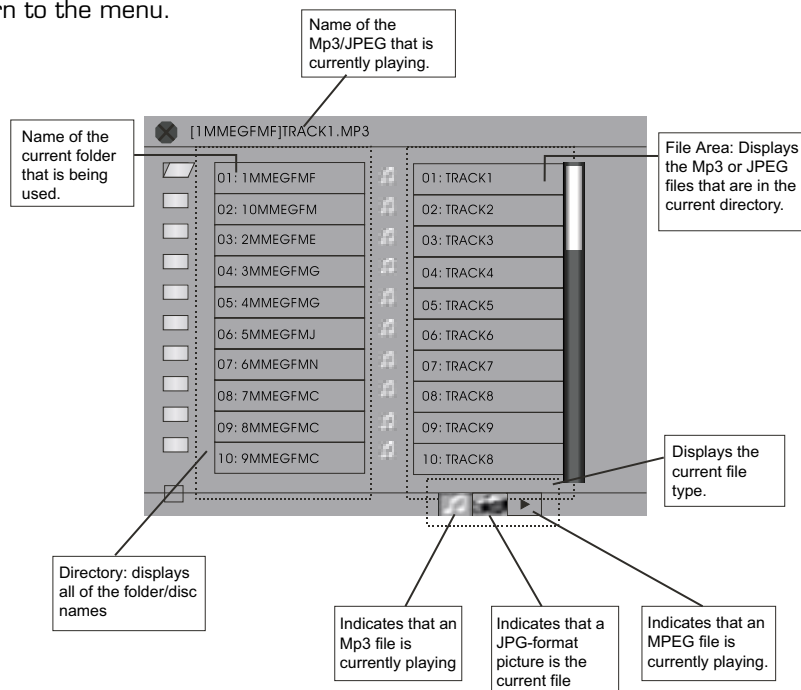

Repeat modes.

There are 3 available repeat modes for files. Access these by pressing the REPEAT button on the PA-MAN's remote control.

REPEAT 1: Repeats the same song.

REPEAT DIR: Repeats the entire directory (folder) once it has played through.

REPEAT ALL: Repeats the whole disc once it has played through.

Removing Modules

Removing the Field Replaceable UHF Modules

Each of the 4 microphone modules on the PA-MAN were designed in a way that allows them to slide out.

This is a convenient feature if ever a module needs to be repaired or replaced.

1. Remove the two screws that fasten the module to the front panel.
2. To remove the module, simply slide the module out of the compartment

NOTE: It might be helpful to use a flat-head screwdriver to nudge the module out of its compartment.

3. To re-insert, slide the module into the compartment until it is completely secured. Secure the module with the screws.

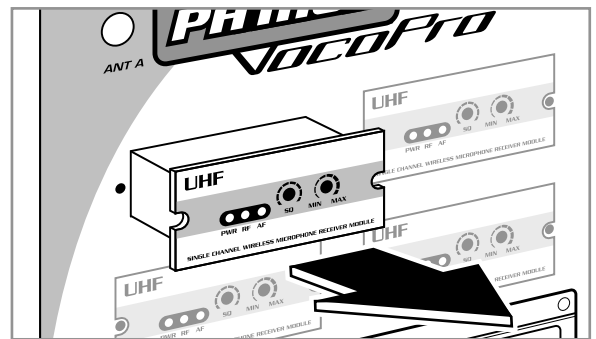
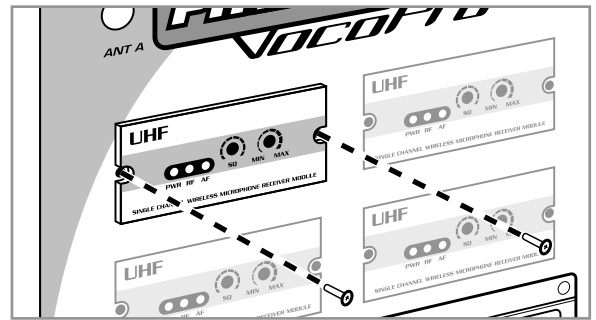

Removing the Disc Player Module

The Multi-Format Disc Player module on the PA-MAN is designed in a way that allows it to slide out.

This is a convenient feature if ever this module needs to be repaired or replaced.

1. Remove the four screws that fasten the module to the front panel.
2. To remove the module, simply slide the module out of the compartment.
3. To re-insert, slide the module into the compartment until it is completely secured. Secure the module with the screws.

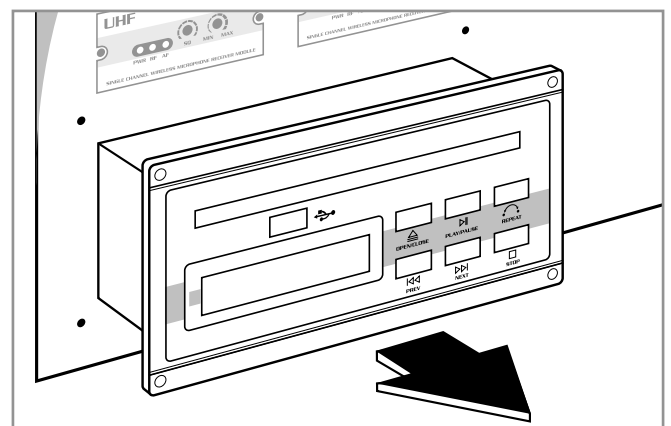
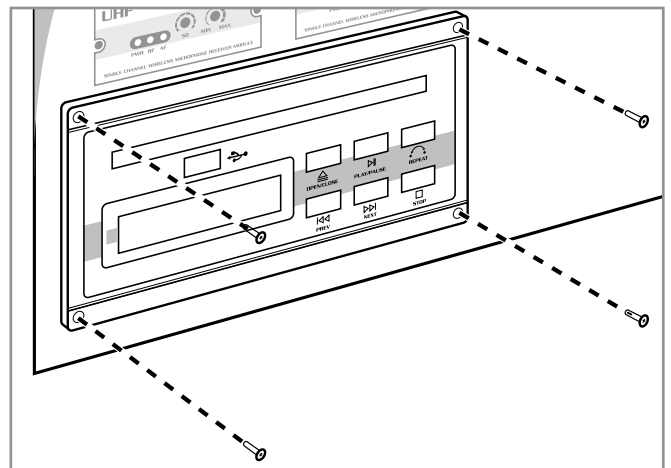

Setting Up Preferences

Press **SETUP** on the remote control to get into the **SETUP** menus. All settings have been preset in the **DEFAULT** mode. This means that the most common settings will already be active when you first setup the **PA-MAN**. It may not be necessary to make any changes for the **PA-MAN** to work correctly.

To exit the **SETUP** screen simply press **SETUP** on your remote or scroll down to **EXIT SETUP** on the **MENU MAIN PAGE** and press **ENTER** on your remote.

System Setup

Press **SETUP** on the remote control and be sure that **SYSTEM SETUP** is highlighted.

1. Tv System

Set the **PA-MAN**'s output to match your TV set's system format. For example, **NTSC** for North American TV systems or **PAL** for European systems. Select **AUTO** if you frequently switch between **PAL** and **NTSC** modes.

2. Screen Saver

When there is no disc or the player is idle for a period of time, screen saver will appear if this setting is **ON**. Using a screensaver can help protect your TV or monitor's screen.

3. Video

Choose the video mode based on what video connection you are using.

NOTE: The PA-MAN only has one video output, this feature is not enabled on the PA-MAN.

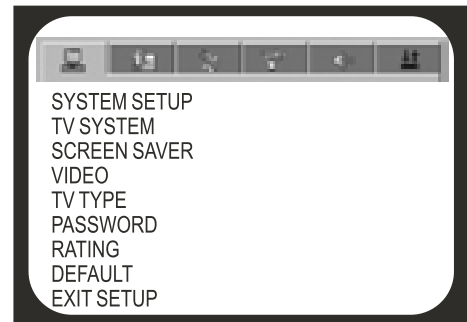

4. TV Type

TV Display Modes: You can select one of the following TV display modes for the video output:

4:3/PS: When the player is connected to a normal (4:3) TV and a wide picture is shown on the full screen, a portion may be cut off automatically.

4:3/LB: When the player is connected to a normal TV and a wide picture is shown on the screen, black strips appear at the top and bottom of the screen.

16:9: When the player is connected to a wide screen TV.

NOTE: If you choose this setting and you don't have a wide screen TV, the images on the screen may appear distorted due to vertical compression.

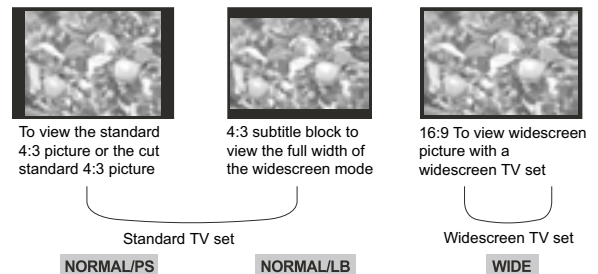

5. Password

Enter your password here, to access parental controls. The first time you use this function, you will have to input the factory-set password which is "0000" and then press enter. You may then input your own password and then press enter again. Be sure that you write down your new password as the factory-set "0000" will not work if you have changed it.

6. Rating

Parents can control the rating of movie that can be shown on the player. Simply select the rating from the list and then press enter. The **LOCK ICON** in the password menu must be unlocked to change the rating.

7. Default

Choosing **RESTORE**, restores the **PA-MAN**'s preferences to the original factory settings.

8. Exit Setup

Exit the setup menu and return to the playback screen.

Setting Up Preferences, cont.

Language Setup

1. OSD Language

The OSD only has two languages: ENGLISH or CHINESE

2. Audio Language

Sets the language for discs with multi-language capabilities.

3. Subtitle Language

Sets the language for the movie subtitles. The disc must be equipped with multi-language subtitles for this to work.

4. Menu Language

Sets the language for DVD menus with multi-language capabilities.

Audio Setup

1. Audio Out

SPDIF/RAW: When using digital output to connect to an amplifier with Dolby decoding, select this option.

SPDIF/PCM: When using digital output for stereo playback.

2. Key

Adjusts the musical key of music to fit the singer's vocal range.

b - Lowers the musical key

h - Resets the music to the original or 'natural' key

- Raises the musical key

Video Setup

1. Brightness

Adjust the brightness of the display using the up and down directional buttons.

2. Contrast

Adjust the contrast of the display using the up and down directional buttons.

3. Hue

Adjust the hue of the display using the up and down directional buttons.

4. Saturation

Adjust the saturation of the display using the up and down directional buttons.

Setting Up Preferences, cont.

The following modes are accessible but not enabled on the PA-MAN. The DVD Decoder used in the PA MAN is standard and not specialized for this unit.

Speaker Setup

1. Downmix

LT / RT: When connecting to a Dolby Digital amplifier.

STEREO: When connecting to a stereo TV or amplifier and the disc supports 2-channel output.

VSS: When using a disc that has been formatted with Virtual Surround Sound.

Digital Setup

1. OP Mode

LINE OUT: This is the standard Digital Output setting.

RF REMOD: When primarily using headphones.

2. Dynamic Range

This selects the Line Out ratio.

NOTE: This can only be used when LINE OUT is chosen in the OP MODE options.

FULL: The audio signal peak value will be the minimum

OFF: The audio signal peak value will be the maximum.

3. Dual Mono

Here you can choose between STEREO, L-MONO, R-MONO, or MIX-MONO output modes. It is usually recommended that you stay in STEREO mode for best results.

Troubleshooting

There is No Power

- Make sure the power cord is firmly connected to the power outlet
- If using a power strip/surge-protector, make sure that it is plugged in and switched on.
- Check to make sure the switch for the component you are using is in the on position.

There is No Sound from Disc

- Make sure everything is connected firmly and properly
- Make sure there are no defective cables
- Make sure all of your components are turned on
- Make sure all of the components (amp, mixer, TV, etc.) are set to the proper inputs

No Picture

- Make sure everything is connected firmly and properly
- Make sure there are no defective cables
- Make sure all of your components are turned on
- Make sure all of the components (amp, mixer, TV, etc.) are set to the proper inputs
- Make sure the TV or monitor is working correctly

The Disc Does Not Play

- Make sure the disc is inserted correctly (label-side up)
- Make sure the disc is clean and not scratched
- If using a CD-R/RW, try using a different brand as some brands might not be compatible
- Clean the CD lens using a CD lens cleaner

The Picture is Unclear

- Make sure the disc is not dirty or damaged
- Make sure that the TV TYPE is set correctly:
NTSC: In North America, Japan and many other Asian countries
PAL: In Europe
- Try restarting the disc player

Troubleshooting, cont.

No Sound Output, RF/AF LED(s) are Not Glowing

- Make sure the microphone and receiver power switches and receiver are set to the ON position.
- Check microphone batteries to ensure that they are providing sufficient power. Replace battery if necessary.
- Check receiver's AC power connection.
- Make sure antennas are firmly connected and extended to an optimal position.
- If necessary, reduce the distance between the microphones and receiver.
- Turn up the receiver's VOLUME level controls.
- Check for proper connection between receiver and external amplifier/mixer.
- Talk into the microphone and observe the receiver's RF/AF signal LED's. If they glow, the problem is elsewhere in the sound system.

Received Signal is Noisy or Contains Extraneous Sounds with the Microphone(s) ON.

- Make sure everything is connected firmly and properly
- Make sure there are no defective cables
- Make sure all of your components are turned on
- Make sure all of the components (amp, mixer, TV, etc.) are set to the proper inputs

There is Noise Coming from the Receiver with the Microphones Turned OFF.

- Remove local sources of UHF interference, such as lighting equipment.
- Reposition the receiver or antennas.

Momentary Loss of Sound as Microphone(s) are Moved Throughout the Operating Range.

- Reposition the receiver, perform a "walkthrough", and observe the signal strengths. If audio dropouts persist, mark these "dead spots" in the operating area and avoid them during the performance.

Notes

VocoPro[®]

THE SINGER'S ULTIMATE CHOICE[™]

