

Instructions for use

SI 29-5

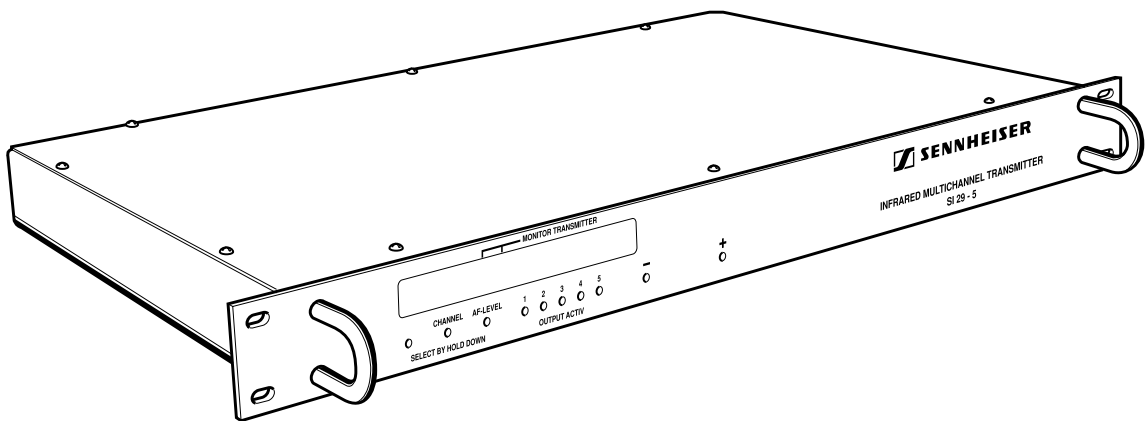

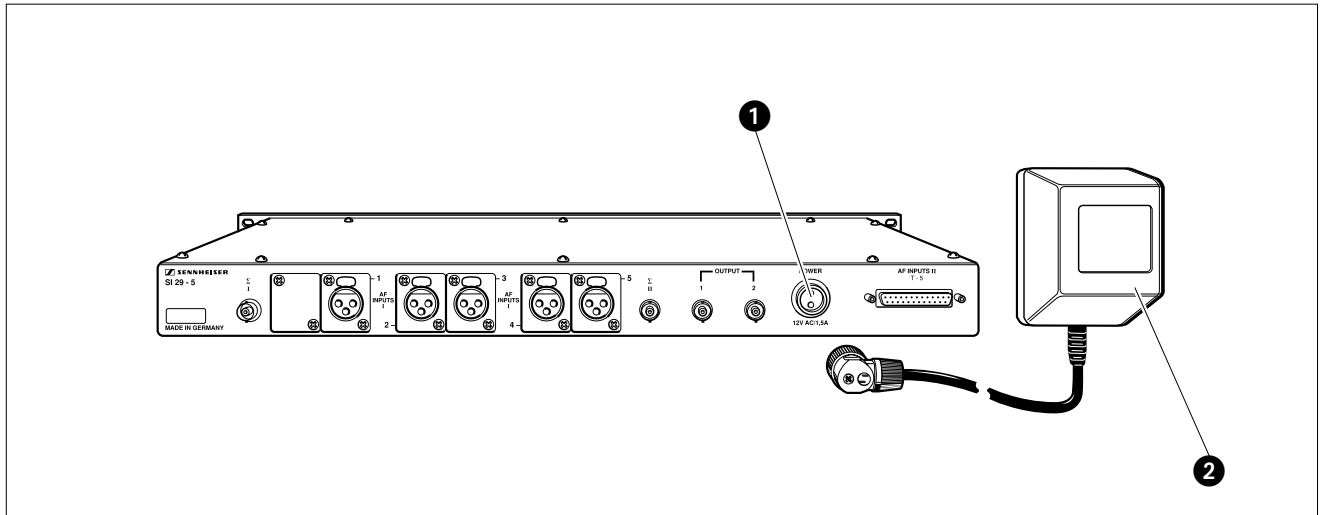

**Putting the IR modulator into operation/power supply**

The SI 29-5 infra-red modulator is powered via the NT 29 plug-in mains unit ②. It is connected to the DC input socket ① by a special twist-lock connector.

The NT 29-5 mains unit is available in different versions, so that the SI 29-5 modulator can be used with the respective voltage of your country:

- NT-29-EU                      230 V 50/60 Hz      Cat. no. 04002
- NT 29-120                    120 V 50/60 Hz      Cat. no. 04003
- NT 29-UK                     240 V 50/60 Hz      Cat. no. 04004

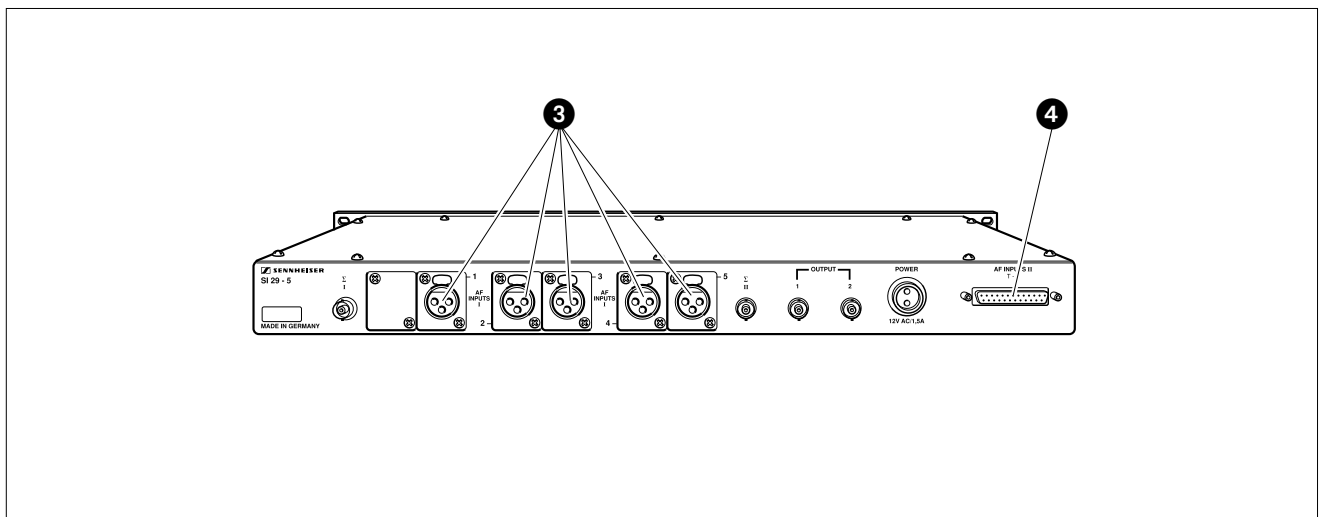

**AF inputs**

Five XLR input sockets ③ for connection of five mono audio signal sources are located at the back of the SI 29-5 infra-red modulator.

The inputs are balanced and floating.

In addition, all inputs are available at the 25-pin D-connector ④. For the connection details of this connector please see the service manual.

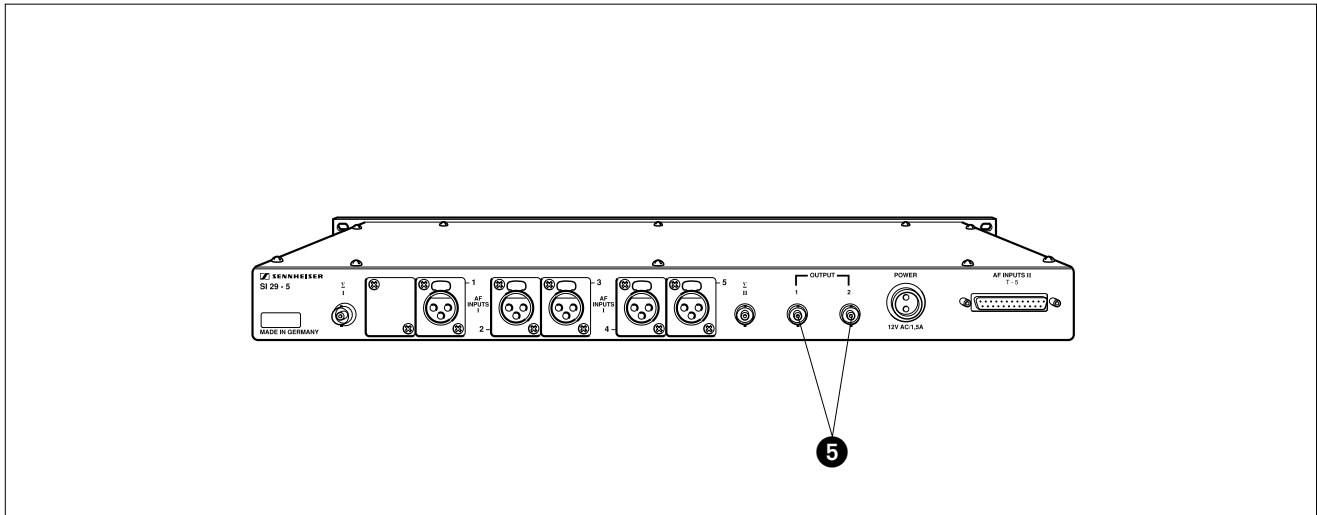

### Connecting IR radiators

Connect the infra-red radiators to sockets ⑤. The SI 29-5 will modulate the infra-red light which will then be radiated by the IR radiators.

You can connect a maximum of 50 radiators to the SI 29-5 modulator. You can also use different radiators (mixed operation):

- SZI 20            Low power infra-red radiator for small rooms, cascadable
- SZI 1029        High power infra-red radiator, IR radiating power 5 W, socket for connection of additional SZI 1029, SZI 1029-10 or SZI 20. Black or unpainted aluminium housing.
- SZI 1029-10    High power infra-red radiator, IR radiating power 10 W, socket for connection of additional SZI 1029, SZI 1029-10 or SZI 20. Black housing.

► **N.B. Please also read the instructions for the IR radiators!**

Avoid very long cable lengths because they lead to signal cancellation when IR radiators are facing one another:

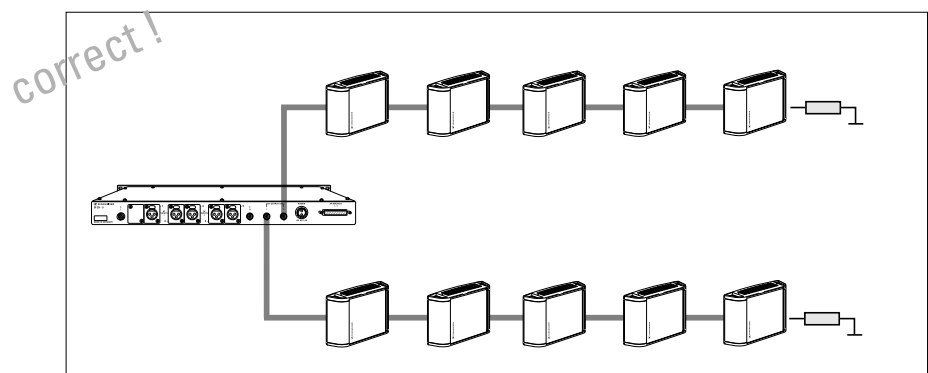
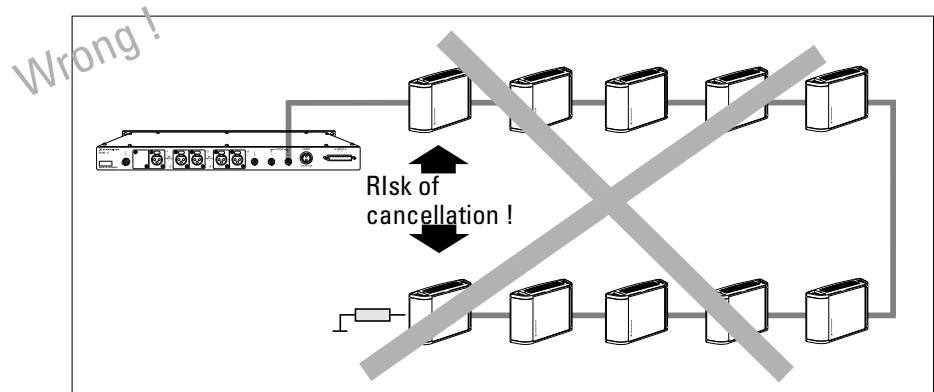

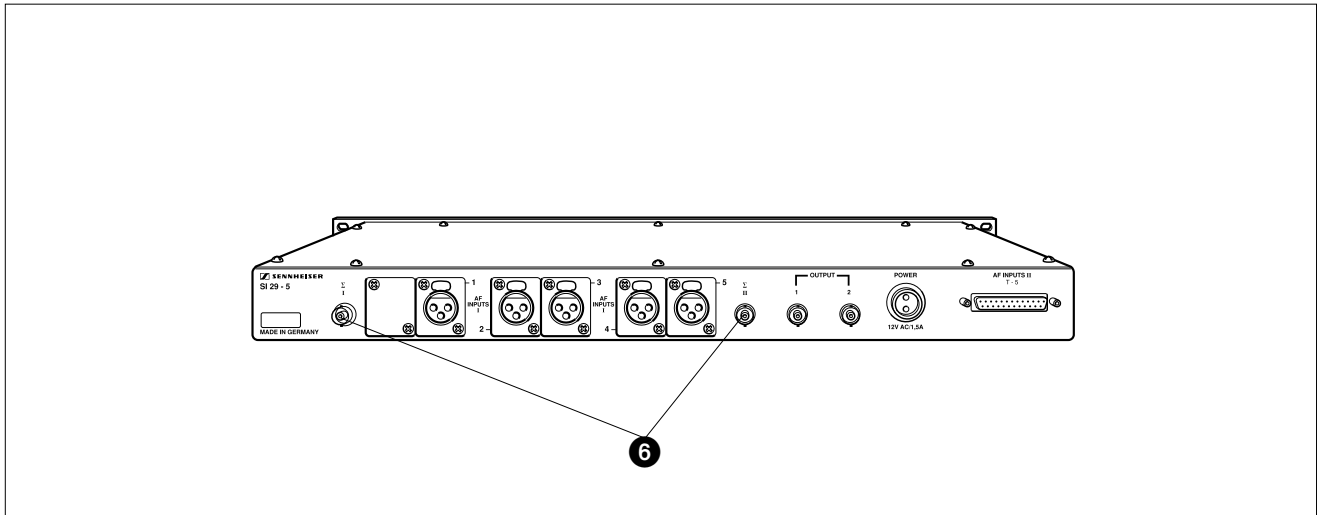

**Connecting several SI 29-5 modulators**

To make a larger system, you can combine several infra-red modulators. In the largest possible system, a maximum of 32 transmission channels can be used:

Number of modulators	Maximum number of transmission channels
1	5
2	10
3	15
4	20
5	25
6	30
7	32

N.B.:

**Do not duplicate channel numbers!**

Cascade the infra-red modulators with a BNC connection cable. Use the cascading sockets ( $\Sigma$ ) 6 for interconnecting. Since these sockets are internally connected in parallel, it does not matter whether you choose the left or the right socket 6.

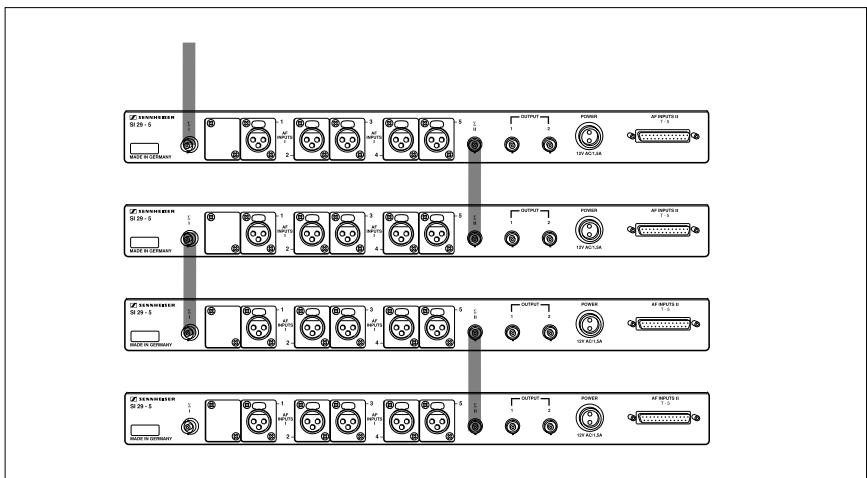

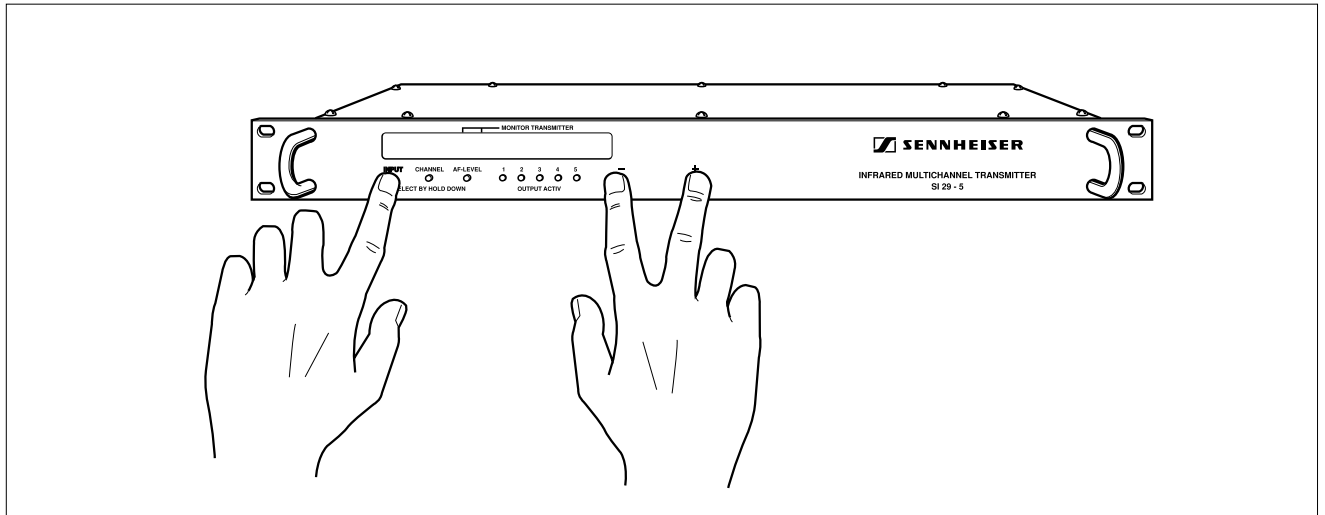

### Choosing the audio input

By **simultaneously** pressing the buttons "INPUT" and "+" or "-", you start the input search for sockets 1 - 5 at the back of the modulator.

With the "+" button you choose a higher input number. Holding this button down initiates fast search, continually cycling from the beginning.

With the "-" button you choose a lower input number. Holding this button down initiates fast search, continually cycling from the beginning.

When both buttons are released the selected input is stored. Now you have to choose the infra-red transmission channel for the selected input.

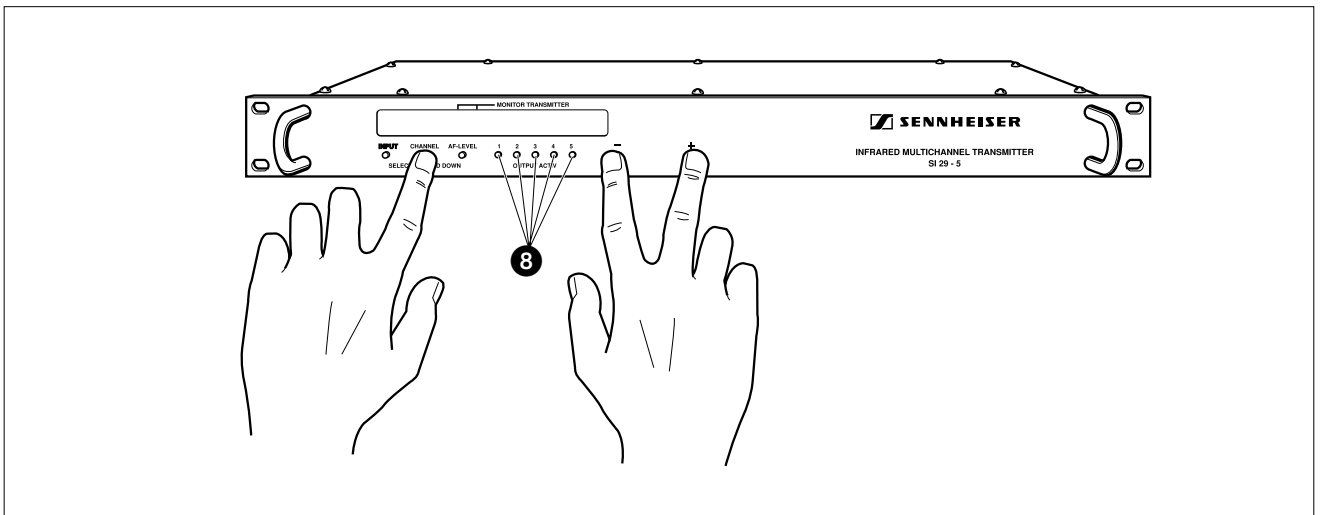

### Choosing the IR transmission channel

By **simultaneously** pressing the buttons "CHANNEL" and "+" or "-" you start the search for the infra-red transmission channel which is to be assigned to the input.

### Switching a channel off

To switch a channel off, search through the transmission channels as described above. The OFF position is the next channel above "31" or below "00" (depending which way you go). The display will indicate "OF." instead of a channel number and the corresponding LED 8 will go off.



**NB: It is important that any unused channels are switched off.** Any channel left on, but unused, will reduce the radiator coverage area accordingly. (See the section on calculating the radiator coverage area in the user manual supplied with the radiator).

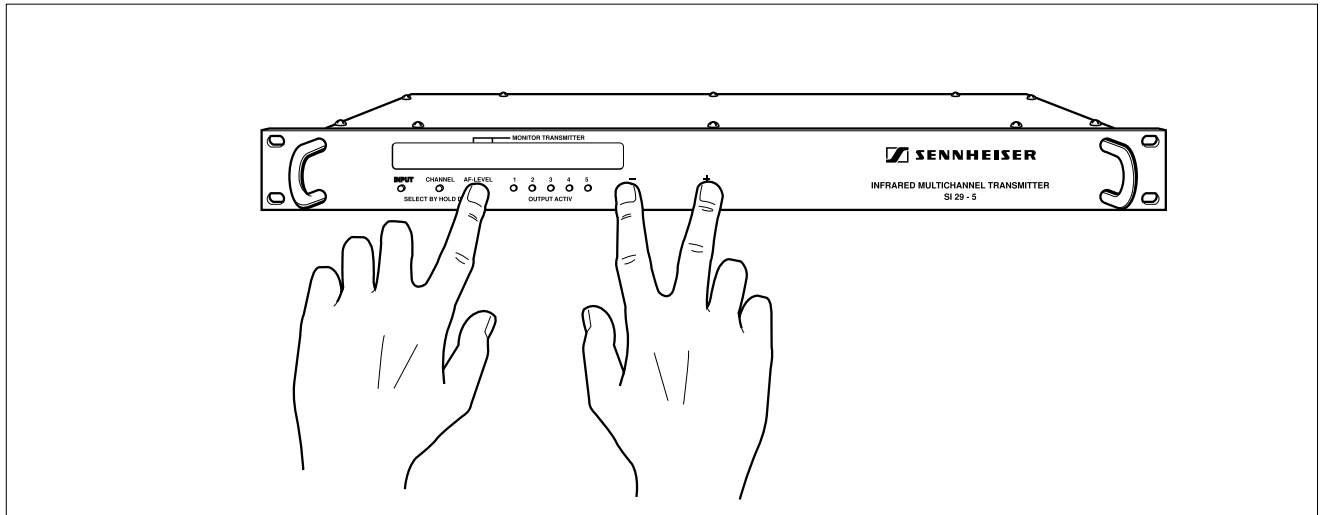

### Adjusting the AF level

By **simultaneously** pressing the buttons "AF LEVEL" and "+" or "-" you can adjust the AF level for the transmission channel you have just selected.

With the "+" button you increase the AF level.  
 With the "-" button you decrease the AF level.

The level is adjusted correctly when the modulation indicator **9** occasionally reaches the red part of the display (full modulation).

When both buttons are released, the selected AF level is stored.

This completes all settings for the first audio input channel. For adjusting the next input channel, start again with **CHOOSING THE AUDIO INPUT**.

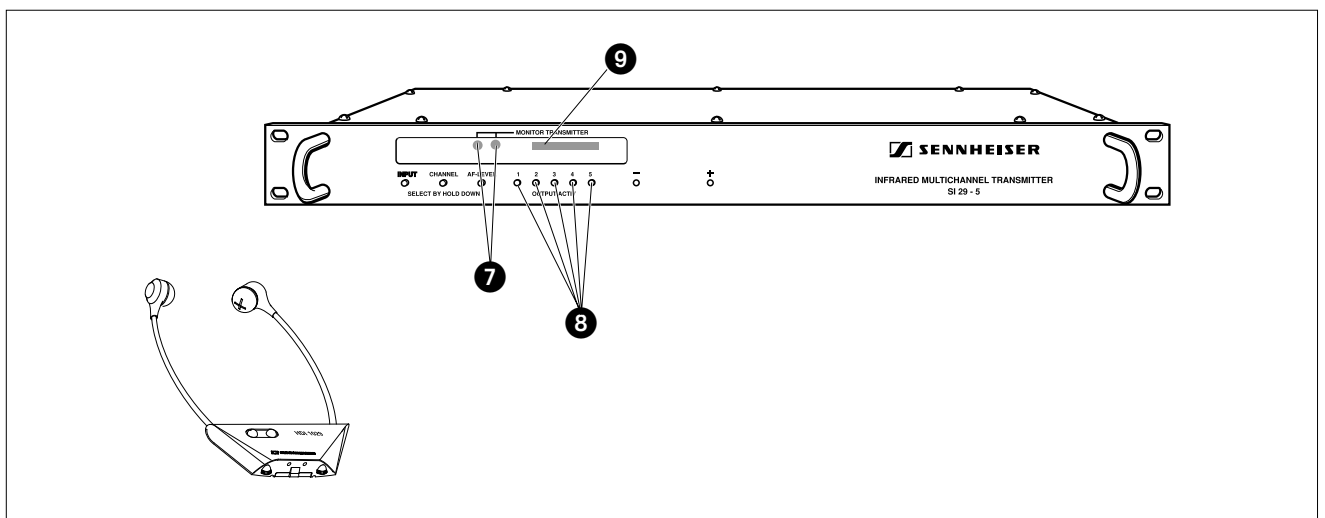

### Monitoring facility

Two infra-red transmission diodes **7** are located behind the display window on the modulator front panel. They transmit the complete infra-red signal for monitoring purposes. Thus you can check the selected transmission channel with a suitable receiver (e.g. an HDI 1029 PLL). The transmission distance of the IR transmitter diodes is approx. 1.2 m.

### Channel display

All transmission channels used are displayed: When a given input delivers its signal to an IR transmission channel, the corresponding LED **8** lights up.

## Technical data

Modulation	narrow-band FM																																																																																																	
Channel frequencies	55 - 1,335 kHz																																																																																																	
Channels:	<table border="0"> <tr><td>Channel 0</td><td>55 kHz</td><td>Display: 00</td></tr> <tr><td>Channel 1</td><td>95 kHz</td><td>Display: 01</td></tr> <tr><td>Channel 2</td><td>135 kHz</td><td>Display: 02</td></tr> <tr><td>Channel 3</td><td>175 kHz</td><td>Display: 03</td></tr> <tr><td>Channel 4</td><td>215 kHz</td><td>Display: 04</td></tr> <tr><td>Channel 5</td><td>255 kHz</td><td>Display: 05</td></tr> <tr><td>Channel 6</td><td>295 kHz</td><td>Display: 06</td></tr> <tr><td>Channel 7</td><td>335 kHz</td><td>Display: 07</td></tr> <tr><td>Channel 8</td><td>375 kHz</td><td>Display: 08</td></tr> <tr><td>Channel 9</td><td>415 kHz</td><td>Display: 09</td></tr> <tr><td>Channel 10</td><td>495 kHz</td><td>Display: 10</td></tr> <tr><td>Channel 11</td><td>535 kHz</td><td>Display: 11</td></tr> <tr><td>Channel 12</td><td>575 kHz</td><td>Display: 12</td></tr> <tr><td>Channel 13</td><td>615 kHz</td><td>Display: 13</td></tr> <tr><td>Channel 14</td><td>655 kHz</td><td>Display: 14</td></tr> <tr><td>Channel 15</td><td>695 kHz</td><td>Display: 15</td></tr> </table>	Channel 0	55 kHz	Display: 00	Channel 1	95 kHz	Display: 01	Channel 2	135 kHz	Display: 02	Channel 3	175 kHz	Display: 03	Channel 4	215 kHz	Display: 04	Channel 5	255 kHz	Display: 05	Channel 6	295 kHz	Display: 06	Channel 7	335 kHz	Display: 07	Channel 8	375 kHz	Display: 08	Channel 9	415 kHz	Display: 09	Channel 10	495 kHz	Display: 10	Channel 11	535 kHz	Display: 11	Channel 12	575 kHz	Display: 12	Channel 13	615 kHz	Display: 13	Channel 14	655 kHz	Display: 14	Channel 15	695 kHz	Display: 15	<table border="0"> <tr><td>Channel 16</td><td>735 kHz</td><td>Display: 16</td></tr> <tr><td>Channel 17</td><td>775 kHz</td><td>Display: 17</td></tr> <tr><td>Channel 18</td><td>815 kHz</td><td>Display: 18</td></tr> <tr><td>Channel 19</td><td>855 kHz</td><td>Display: 19</td></tr> <tr><td>Channel 20</td><td>895 kHz</td><td>Display: 20</td></tr> <tr><td>Channel 21</td><td>935 kHz</td><td>Display: 21</td></tr> <tr><td>Channel 22</td><td>975 kHz</td><td>Display: 22</td></tr> <tr><td>Channel 23</td><td>1015 kHz</td><td>Display: 23</td></tr> <tr><td>Channel 24</td><td>1055 kHz</td><td>Display: 24</td></tr> <tr><td>Channel 25</td><td>1095 kHz</td><td>Display: 25</td></tr> <tr><td>Channel 26</td><td>1135 kHz</td><td>Display: 26</td></tr> <tr><td>Channel 27</td><td>1175 kHz</td><td>Display: 27</td></tr> <tr><td>Channel 28</td><td>1215 kHz</td><td>Display: 28</td></tr> <tr><td>Channel 29</td><td>1255 kHz</td><td>Display: 29</td></tr> <tr><td>Channel 30</td><td>1295 kHz</td><td>Display: 30</td></tr> <tr><td>Channel 31</td><td>1335 kHz</td><td>Display: 31</td></tr> </table>	Channel 16	735 kHz	Display: 16	Channel 17	775 kHz	Display: 17	Channel 18	815 kHz	Display: 18	Channel 19	855 kHz	Display: 19	Channel 20	895 kHz	Display: 20	Channel 21	935 kHz	Display: 21	Channel 22	975 kHz	Display: 22	Channel 23	1015 kHz	Display: 23	Channel 24	1055 kHz	Display: 24	Channel 25	1095 kHz	Display: 25	Channel 26	1135 kHz	Display: 26	Channel 27	1175 kHz	Display: 27	Channel 28	1215 kHz	Display: 28	Channel 29	1255 kHz	Display: 29	Channel 30	1295 kHz	Display: 30	Channel 31	1335 kHz	Display: 31
Channel 0	55 kHz	Display: 00																																																																																																
Channel 1	95 kHz	Display: 01																																																																																																
Channel 2	135 kHz	Display: 02																																																																																																
Channel 3	175 kHz	Display: 03																																																																																																
Channel 4	215 kHz	Display: 04																																																																																																
Channel 5	255 kHz	Display: 05																																																																																																
Channel 6	295 kHz	Display: 06																																																																																																
Channel 7	335 kHz	Display: 07																																																																																																
Channel 8	375 kHz	Display: 08																																																																																																
Channel 9	415 kHz	Display: 09																																																																																																
Channel 10	495 kHz	Display: 10																																																																																																
Channel 11	535 kHz	Display: 11																																																																																																
Channel 12	575 kHz	Display: 12																																																																																																
Channel 13	615 kHz	Display: 13																																																																																																
Channel 14	655 kHz	Display: 14																																																																																																
Channel 15	695 kHz	Display: 15																																																																																																
Channel 16	735 kHz	Display: 16																																																																																																
Channel 17	775 kHz	Display: 17																																																																																																
Channel 18	815 kHz	Display: 18																																																																																																
Channel 19	855 kHz	Display: 19																																																																																																
Channel 20	895 kHz	Display: 20																																																																																																
Channel 21	935 kHz	Display: 21																																																																																																
Channel 22	975 kHz	Display: 22																																																																																																
Channel 23	1015 kHz	Display: 23																																																																																																
Channel 24	1055 kHz	Display: 24																																																																																																
Channel 25	1095 kHz	Display: 25																																																																																																
Channel 26	1135 kHz	Display: 26																																																																																																
Channel 27	1175 kHz	Display: 27																																																																																																
Channel 28	1215 kHz	Display: 28																																																																																																
Channel 29	1255 kHz	Display: 29																																																																																																
Channel 30	1295 kHz	Display: 30																																																																																																
Channel 31	1335 kHz	Display: 31																																																																																																
Nominal/peak deviation	± 6 kHz / ± 7 kHz																																																																																																	
Amplitude limitation	limiting amplifier (max. 30 dB)																																																																																																	
Deviation display	via 12 LEDs: Peak, 5 dB, 3 dB, 1 dB, 0 dB, -1 dB, -3 dB, -5 dB, -7 dB, -10 dB, -15 dB, -20 dB																																																																																																	
AF inputs	5 transformer balanced XLR-3 inputs or a 25-pin SUB-D connector																																																																																																	
AF input sensitivity	50 mV - 2.5 V (line) The modulator input can optionally be fitted with microphone sensitivity (0.5 mV - 30 mV which can be done by your local Sennheiser dealer. The modulator can also be equipped for a phantom powered microphone.																																																																																																	
AF frequency response	50 - 12,000 Hz																																																																																																	
THD	< 0.5 %																																																																																																	
AF signal-to-noise ratio	> 70 dB(A) eff.																																																																																																	
RF output	2 x BNC (short-circuit proof), 0.6 V 2 x BNC (summing node, for connecting several radiators), 30 mV																																																																																																	
Output impedance	approx. 50 Ω																																																																																																	
Suppression of harmonics	> 60 dB																																																																																																	
Power supply	via plug-in mains unit, 12 V AC, 20 W																																																																																																	
Power consumption	max. 17 W																																																																																																	
Dimensions	485 x 340 x 45 (1 U for installation in a 19" rack)																																																																																																	
Weight	approx. 4.0 kg																																																																																																	

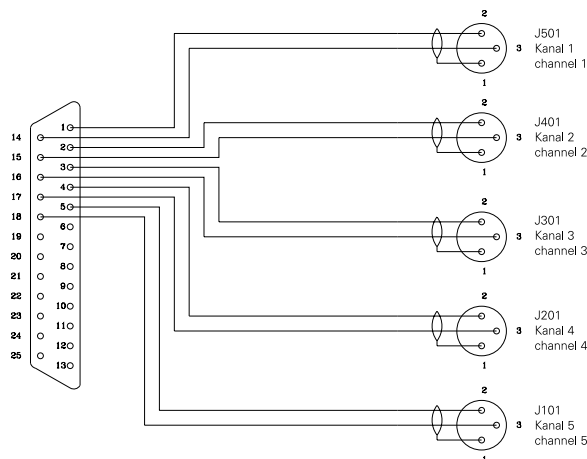

Subject to alterations



Sennheiser electronic GmbH & Co. KG  
D-30900 Wedemark  
Telefon: 05130/600-0  
Telefax: 05130/600-300

Printed in Germany  
Publ. 6/97 54598 / A03