

EDIT

KONA

Power and Quality
for Professionals



Because it matters.

AJA[®]
VIDEO SYSTEMS

KONA

Solid performance and powerful features.
Unparalleled reliability. Built for video professionals by video professionals.

KONA Connects.

KONA capture, display and mastering solutions for SD, HD, 3G, Dual Link HD and 2K on a Mac or PC lie at the heart of your post-production process.

The working professional—whether non-linear editor, compositor, motion graphics or 3D artist—needs to connect their software with a range of hardware.

KONA cards installed in your Mac or PC bring the world to you and your creativity to the world.

Ingest from Analog or Digital sources, such as Decks and Cameras.

Display your work in action on Broadcast Monitors, Plasmas and Projectors.

Monitor your multi-track audio through your Mixers and Speakers.

Master your project to HD and SD simultaneously on Digital or Analog tapes or disks.

It's in the hardware.

Master all formats with KONA.

In a world of myriad HD standards, SD needs, 2K beauty, and growing 3D stereoscopic workflows, KONA cards offer maximum connectivity like 3G/HD/SD SDI, Component, and HDMI, along with the flexibility of superior conversion capability, allowing you to place the needs of your project first.

Unburden your CPU.

Within supported applications, KONA's Hardware Scalar Acceleration takes a portion of the codec processing load off the CPU, allowing your computer to concentrate on what you care about, more RealTime effects.

No more rendering for raster resizing. KONA's superior "always-on" 10-bit hardware-based Up/Cross/Down conversion offers you the ability to ingest to the standard of your project while displaying and mastering live simultaneously to HD and SD as your needs require.

INGEST, EDIT, MONITOR and MASTER

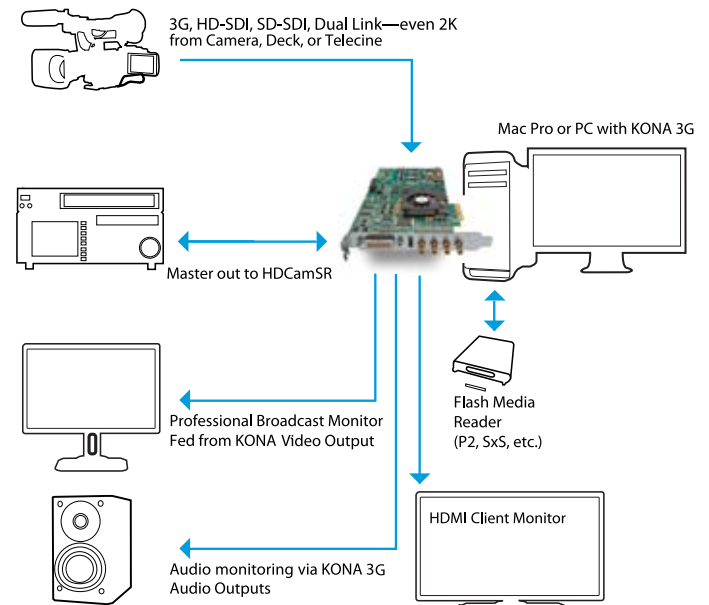

Connect your digital sources via SD/HD SDI to KONA for capture and editing via a wide variety of formats

Master to any Digital or Analog deck through high-quality professional SDI or Component outputs.

The KONA Family

KONA capture cards are available in three distinct flavors to meet your workflow needs. From the cost conscious KONA LSe, affordable and flexible KONA LHi, to the top of the line KONA 3G with extended connectivity, AJA's reputation for Quality, Reliability and Support is evident in each.



| KONA features | KONA 3G | Dynamic RTExtreme hardware scaling acceleration | | |
|-------------------------------------------------------------------|---------------------------------------|-------------------------------------------------|---------------------------------------|------------------------|
| | | Mac Mac | KONA LHi | KONA LSe |
| SD (NTSC and PAL) | yes | - | yes | yes |
| HD (720p, 1080i, 1080sf) | yes | yes | yes | - |
| 2K (2048 x 1556, 2048 x 1080) Dual-Link HD, 2K HSDL, 4:4:4 RGB | yes | - | 2K x 1080 video at 4:2:2, non-RGB | - |
| 3G SDI | yes | - | yes | - |
| HDMI | HDMI 1.4a output | - | HDMI 1.3a input/output | - |
| HD to SD Down-conversion (10-bit, in hardware) | yes | - | yes | - |
| SD to HD Up-conversion (10-bit, in hardware) | yes | - | yes | - |
| HD to HD Cross-conversion (1080 to/from 720, 10-bit, in hardware) | yes | - | yes | - |
| 12-bit Analog Video (component, Composite, and Y/C) | output SD/HD | - | input/output SD/HD | input/output SD |
| 10-bit SDI Digital Video (BNC) | input/output SD/HD/3G | - | input/output SD/HD/3G | input/output SD |
| HD Video+Key | yes | - | - | - |
| Analog Audio (balanced XLR) | - | - | input/output 2-channel | input/output 2-channel |
| AES Digital Audio | 8-ch I/O w/cable, 16-ch I/O w/K3G-Box | - | input/output 2-channel | input/output 2-channel |
| Embedded SDI Audio (via BNC) | input/output 16-channel | - | input/output 8-channel | input/output 8-channel |
| Professional Genlock | yes | - | yes | yes |
| LTC Input/Output | yes | - | LTC input (shared with reference BNC) | - |
| RS-422 Machine Control | yes | - | yes | yes |
| 1RU Breakout Box (optional) | yes | - | yes | yes |
| 3-year AJA Warranty with Advanced Exchange | yes, included | - | yes, included | yes, included |
| Support for DPX, Cineon, and DVCPRO HD | Mac/PC | - | Mac/PC | PC |
| Native support for TGA, TIF, BMP, YUV, AVI and QuickTime | Mac/PC | - | Mac/PC | Mac/PC |
| DVCPRO HD hardware scaling acceleration | Mac/PC | - | Mac/PC | - |
| HDV hardware scaling acceleration | Mac/PC | - | Mac/PC | - |
| Dynamic RTExtreme hardware scaling acceleration | Mac | - | Mac | - |

KONA for Mac Software



AJA KONA for Mac drivers are optimized for use on OSX, with applications and advanced AJA hardware capabilities controlled easily at-a-glance in the application you're using. KONA for Mac software integrates within the native environment where used—whether Apple Final Cut Studio, Adobe Creative Suite, Autodesk Smoke for Mac, or a wide array of other Mac applications.

Within Apple Final Cut Pro, KONA offers:

- Easy Setups for instant configuration of your workflow in unison with KONA hardware.
- Advanced hardware configuration from the AJA Control Panel can be accessed without leaving your application by simply holding down the command key and clicking into the UI.



For example, play back HD media from Final Cut Pro and evaluate what an SD downconversion would look like as an anamorphic, cropped or letterboxed output - all in realtime without ever stopping playback.

- HDV codec hardware acceleration. The KONA hardware allows instantaneous realtime playback for both monitoring and recording. Even KONA's conversions work in realtime with HDV, allowing SD monitoring, dubs, or mastering.
- DVCPRO HD codec hardware acceleration. KONA's precision hardware allows capture and playback of HD-SDI video to and from the DVCPRO HD codec at a quality level virtually indistinguishable from native FireWire, while freeing up valuable RT processing power.
- Dynamic RT Extreme video scaling support. Dynamic RT Extreme video scaling is offloaded in realtime to KONA as the "Playback Video Quality" dynamically adjusts. This allows more playback power - and because KONA handles it seamlessly, the Dynamic RT you see on the Mac monitor is the same as that shown on your professional broadcast monitor output from the KONA card.

Within Adobe Creative Suite

- Advanced AJA Plug-ins support offering control of KONA using familiar controls and appearance within Adobe CS applications including Premiere, Photoshop, and After Effects.
- Realtime Photoshop broadcast video output to broadcast monitors.
- Realtime Capture, Display and Mastering from within After Effects.
- Saved software rendering time with hardware-based KONA Up/Cross/Down Conversion.
- Native realtime support for file per frame formats such as DPX, Cineon, TIFF, TGA and BMP.

All Mac Applications benefit

The KONA Desktop feature allows broadcast design elements to be viewed with the proper aspect ratio and color depth on a broadcast monitor via the KONA card. KONA Desktop is available on the entire range of KONA cards, supporting Adobe After Effects, Photoshop, Apple Motion, Apple Shake, Autodesk Combustion and more.

Powerful AJA utilities, Easy Setups, and plug-ins round out the Mac environment providing support for all popular Mac application workflows.



KONA for PC Software



KONA for PC software allows Windows to access the hardware power of your KONA within major editing and graphics applications. Other software vendors have also provided integrated support for KONA in their own PC applications through direct collaboration with AJA.

Choose the right KONA card to playback HD/SD or SD-only video and audio data from disk—even 2K—in any format you choose, including DPX, Cineon, TGA, TIFF, BMP, AVI and QuickTime. You can playback and master material, at a variety of frame rates, on a high-resolution wide-screen monitor or digital projector. Custom AJA software allows full control over your playback parameters are clearly laid out, including provisions for choosing a user-specified LUT.

Powerful plug-ins

Supplied AJA plug-ins integrate your KONA card into a variety of graphics/visual-effects software applications to make operations even easier to use. Using AJA plug-ins, sophisticated features appear as if they were native to the software application user interfaces. Directly supported applications include:

- Adobe Premiere® Pro
- Adobe After Effects®
- Adobe PhotoShop®
- Autodesk Combustion®
- Eyeon Digital Fusion®



All Workflows benefit from AJA Machina

KONA for PC software includes a stand-alone powerful capture/playback application, AJA Machina™, that includes full VTR machine control with access to any and all KONA supported file formats, video standards and hardware conversions, presented in a very cool and easy-to-use interface. Machina supports all KONA for PC formats, including DVCPRO HD, QuickTime, DPX and many others.

Files captured from Machina can be imported into virtually any software package that supports these file formats, such as compositing programs, 3D animation programs, audio editing programs and much more. Exported files from your application of choice can be seamlessly played out to the video and audio equipment of your choice.

Machina has great desktop preview features allowing you to preview your files full screen on your desktop display at various zoom levels, creating an alternative for frame by frame viewing when no additional monitor is available. In addition Machina allows you to apply 1D LUT's on output, to output video+key for monitoring or mixing, and the ability to key in static graphics on selected KONA cards.

This huge feature set makes Machina an invaluable Windows tool for film and video professionals, making it a useful addition to virtually any PC workflow.



It's in the software

AJA uniquely offers not only the driver software support, optimized platform compatibility and plug-ins you expect for leading editing and graphics applications like Apple Final Cut Studio on the Mac or Adobe Creative Suite on a Mac or PC, but also a range of additional standalone software applications that extend your power and capability.



AJA Control Panel

All KONA cards ship with the AJA Control Panel for control and configuration of your KONA hardware before ingest and live during display on your Mac. Want to experiment live with SD downconversion while your HD timeline plays and your client chooses? AJA makes it possible.



VTR Xchange (Mac) and AJA Machina (PC)

Uniquely control and configure your KONA hardware before ingest and live during display. Ingest, Master, Connect and control your deck through RS-422. Capture and playback myriad file formats, including high-end file-per-frame.



AJA DataRate Calculator

Calculate your storage needs before digitizing even begins and keep your team on track.



AJA System Test

Tune your system to the same high standards that developers do for the best performance.



AJA TV

Need to quickly show a KONA QuickTime or Sequence to a client in a rush? Don't fire up your whole NLE application, output in realtime through AJA TV.



AJA KONA QTTToDPXTranslator and AJA KONA DPXToQTTTranslator

Take a 2K or HD 10-bit RGB QuickTime movie captured with your KONA 3G and translate it to file-per-frame DPX or accomplish the opposite. Work in realtime with DPX source files within Final Cut Studio. Only AJA makes it possible.



It's the Compatibility

Visual artists have a range of software applications and platforms they prefer and need to work with. No other manufacturer can match the breadth of application support and needs of the working professional. Pick your application of choice and KONA connects it to your world.

| Software Compatibility | KONA 3G | KONA LHi | KONA LSe |
|--------------------------|---------|----------|----------|
| Apple Final Cut Pro | Mac | Mac | Mac |
| Apple Color | Mac | Mac | Mac |
| Apple Motion | Mac | Mac | Mac |
| Apple Soundtrack | Mac | Mac | Mac |
| Apple Logic | Mac | Mac | — |
| Adobe Premiere Pro | Mac/PC | Mac/PC | Mac/PC |
| Adobe After Effects | Mac/PC | Mac/PC | Mac/PC |
| Adobe PhotoShop | Mac/PC | Mac/PC | Mac/PC |
| MacCaption | Mac | — | — |
| AJA TV | Mac | Mac | Mac |
| AJA VTR Xchange | Mac | Mac | Mac |
| AJA Machina | PC | PC | PC |
| AJA Data Rate Calculator | Mac/PC | Mac/PC | Mac/PC |
| AJA System Test | Mac/PC | Mac/PC | Mac/PC |
| Autodesk Smoke On Mac | Mac | — | — |
| Autodesk Combustion | PC | PC | PC |
| Drastic Media NXS | PC | PC | PC |
| Sony Vegas | PC | PC | — |
| Eyeon Fusion 64 bit | PC | PC | PC |
| CineForm Prospect HD | PC | PC | — |
| CineForm Prospect 4K | PC | PC | — |
| CineForm Neo HD | Mac/PC | Mac/PC | — |
| CineForm Neo 4K | Mac/PC | Mac/PC | — |
| The Foundry Nuke | Mac/PC | Mac/PC | — |
| Media 100 | Mac | Mac | — |
| Softtron | Mac | Mac | — |
| Gallery | Mac | Mac | — |
| Building4Media | Mac | Mac | — |
| Bug.tv | Mac | Mac | — |
| ToolsOnAir | Mac | Mac | — |
| Red Workflow | Mac/PC | — | — |
| ARRI Alexa Workflow | Mac/PC | — | — |

Cross-Platform Power

When looking for a cross-platform hardware solution, KONA is an excellent fit. KONA can be used interchangeably in either Mac OSX or Windows. Use it in an Apple Mac Pro running Boot Camp and you've got the best of both worlds: compressed and uncompressed files captured on one OS, that can be moved and used on the other. KONA allows users the freedom to use applications on different platforms, or collaborate with users on opposite platforms and pass assets between each other without having to render each time. KONA supports QuickTime ingest and playback on both OSX and Windows, allowing seamless and elegant file interchange between operating systems.

KONA^{3G}

Power. Performance. Price.
Multi-format SD/HD/Dual Link/3G/2K
Video I/O



KONA 3G has the unparalleled features top of the line video professionals expect from AJA Desktop solutions.

KONA 3G features 10-bit Uncompressed video I/O, the newest HDMI 1.4a support for 3D workflows, 16-channel SDI embedded audio I/O, and up to 16-channel AES digital audio I/O (8 with breakout cable or 16 with optional K3G-Box). Add to that realtime hardware-based up/down/cross conversion for efficiently working with a wide variety of SD and HD, 3G, dual-link HD, even 2K formats, a hardware downstream keyer for compositing graphics without rendering, and so much more.

3D Stereoscopic flexibility

KONA 3G offers you the most affordable and simplest path through 3D Stereoscopic workflows.

Through SDI, you can output Discrete Left and Right Eye feeds with a simple Stereo button choice in the AJA control panel. In addition, all the muxed feeds for SDI stereo monitoring are accessible through tight integration with CineForm's stereo codecs in Apple FCP and Adobe CS5 timelines for Side by Side, Top Bottom and so much more.

Through HDMI 1.4a, you can utilize more affordable 3D displays for your monitoring needs.

KONA 3G offers you Stereo Simplicity.

Broadcast-quality conversions

KONA 3G features full 10-bit, broadcast-quality, motion-adaptive SD to HD up-conversion, HD to HD cross-conversion, HD to SD down-conversion, and automatic HD/SD 12-bit component analog output. Since all conversion functionality on the KONA 3G is hardware-based, it's available all the time on ingest or playback.

Uniquely, the KONA 3G can even cross-convert 720p 23.98 to 1080PsF 23.98. Cross-conversion is particularly valuable in today's multi-format HD post environment where being able to produce pristine 720p or 1080i signals at-will helps streamline dailies and deliverables creation.

Internal SD/HD hardware downstream keyer

The AJA KONA 3G features a powerful hardware downstream keyer that can place graphic files with an alpha channel over the video being input to the board—or a selectable color matte, or the contents of the card's framebuffer (ex: AJA TV/Apple Final Cut Pro). The downstream keyer can also key a QuickTime video clip that has an alpha channel by playing it in realtime, via the supplied AJA TV application, over live video coming into the card.

Connectivity

For SDI video, the card features two 3G/HD/SD-SDI inputs and two outputs, HDMI 1.4a monitoring output, LTC input and output, one connection for Genlock input, and configurable 3x BNC HD/SD analog video output. Also included is a 9-pin connector for RS-422 machine control. If you're using a Digital Betacam, DVCPRO50, HDCAM, DVCPRO HD, D5, or HDCAM SR VTR—or any other professional device—you'll have the proper connections.

Dual link HD support

KONA 3G supports Dual Link 4:4:4 HD-SDI, with full bandwidth 4:4:4 RGB at 10-bits for 1080i, 1080p, 1080PsF and 720p formats. KONA 3G can also convert between 4:4:4 and 4:2:2 formats for single link HD-SDI monitoring and output.

2K support

As the most capable 2K card for the Mac, you can use KONA 3G to ingest from 3G or HSDL (high speed data link) equipped sources and record at full frame rate or record simultaneous 2K DPX files and 2K QuickTime reference movies using the AJA VTR Xchange application. You can also work with existing 2K material, like sequential DPX or Cineon files, by using AJA's DPXToQT Translator application to create QuickTime files for a wide variety of applications. RED Epic and ARRI Alexa workflows are eased by KONA 3G, with true realtime 2K playback and LUT support.

On a PC, KONA 3G can connect to a 2K telecine saving time and steps by directly creating 2K DPX, QuickTime, Cineon, AVI, TGA, TIFF or BMP files. Users can capture directly into the format they need and move files immediately into their editing/compositing environment of choice. These same files can be played out at 2K via 3G or High Speed Data Link (HSDL), offering further synergy with other 2K products already in use in the market.

KONA 3G also allows 2K files to be viewed with a user selected crop function on HD 1080PsF supported video monitors. This functionality helps lower the price barrier for viewing 2K material.

The 1080 HD payout can additionally be down-converted to SD in realtime, giving users a powerful solution for multi-format video payout of 2K material and flexible tape mastering options.

Audio

Tie the KONA 3G to a digital audio mixer or DAW output with 8-channel 24-bit 48kHz or 96kHz AES audio via BNC connections on the supplied breakout cable—or get the optional K3G-Box to output an even larger 16-channels of AES audio.

KONA 3G’s high-quality input sample-rate conversion on AES inputs eliminates the need for audio source synchronization.

For multi-channel audio mastering, 16-channel SDI embedded 24-bit 48kHz audio provides the power you need to integrate into any audio environment.

Extend your Connectivity with K3G-Box for KONA 3G

The optional K3G-Box simplifies connectivity in professional post-production environments by offering a 19-inch, 1RU rack-mountable breakout box that attaches to the KONA 3G via an included multi-pin cable and two cables supplied with the KONA 3G. Additional K3G-Box functionality over the standard breakout cable comes in the form of 8 additional AES audio channels, 2-channel RCA analog audio monitoring jacks, and looping BNC Genlock reference connectors.



KONA 3G breakout cables (supplied)

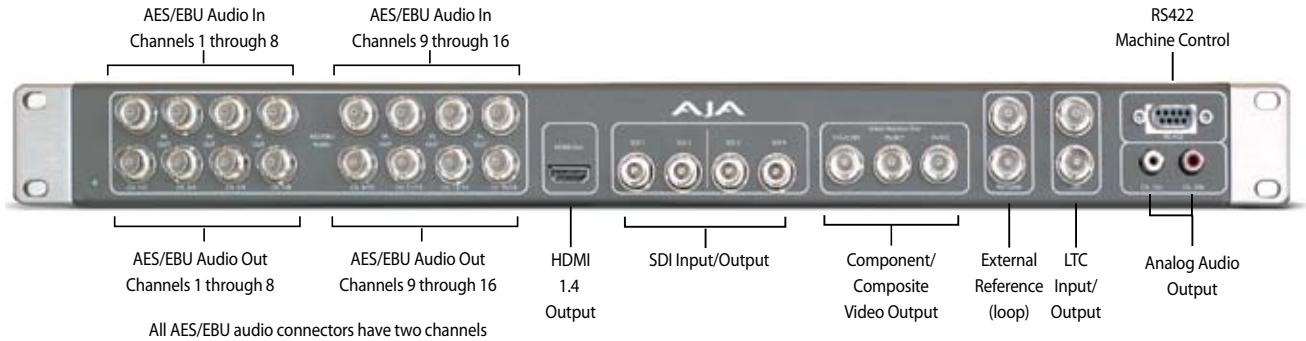

K3G-Box for KONA 3G (Optional)

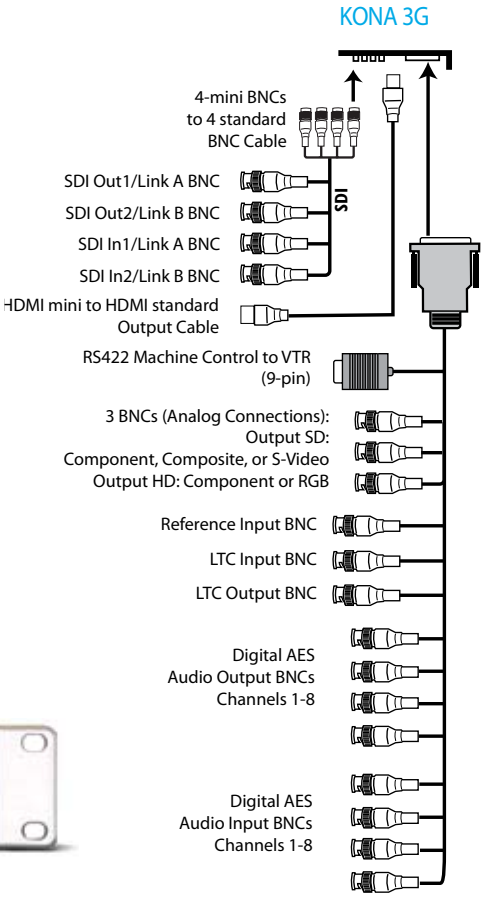

KONA 3G breakout cables (3 supplied)

KONA^{LHi}

The Most Flexible Card for Analog and Digital Standard and High Definition Workflows



The AJA KONA LHi bridges the gap between legacy analog devices and the latest 3Gb SDI and HDMI enabled products providing editing, monitoring and mastering of professional quality video in an affordable, powerful, easy to use product.

Connectivity

If your post-production facility works with a wide variety of formats, frame rates and audio/video sources, the AJA KONA LHi provides the connectivity you need.

Connect everything from an HDMI enabled camera to an HD-SDI VTR to KONA LHi. Connecting to any of your legacy analog video signals is also possible through configurable component, composite, or s-video. Via an Input PassThrough mode, you can even configure the card to act as a converter within your computer.

KONA LHi offers a full host of no-compromise features: 10-bit or 8-bit uncompressed video, 2-channel AES digital audio and 8-channel SDI embedded digital audio, analog composite or s-video or SD/HD component video I/O, 2-channel balanced analog audio I/O, and broadcast-quality hardware-based up/down/cross-conversion for flexible SD and HD post production.

KONA LHi's HDMI 1.3a support allows you to feed a "deep color" monitor with glorious 10-bit video, banishing video banding and preserving your gradients and rich color palate. Only KONA LHi delivers this 10-bit deep color state-of-the-art HDMI support.

Broadcast-quality conversions

Like the AJA KONA 3G product, the KONA LHi features full 10-bit, broadcast-quality, motion-adaptive SD to HD up-conversion, HD to HD crossconversion, HD to SD down-conversion, and automatic HD/SD 12-bit component analog output. Since KONA LHi's conversions are hardware-based, they are available all the time - during ingest or playback. Outputs can be configured independently allowing you to have simultaneous HD and SD output - or two different types of HD - 720 or 1080 - output at the same time via cross-conversion.

Extend your Connectivity with KLHi-Box

The optional KLHi-Box provides all the standard features of a cable for 1RU rack mounted I/O convenience and added connectivity in the form of additional BNC digital AES/EBU connectors and RCA audio monitoring jacks.

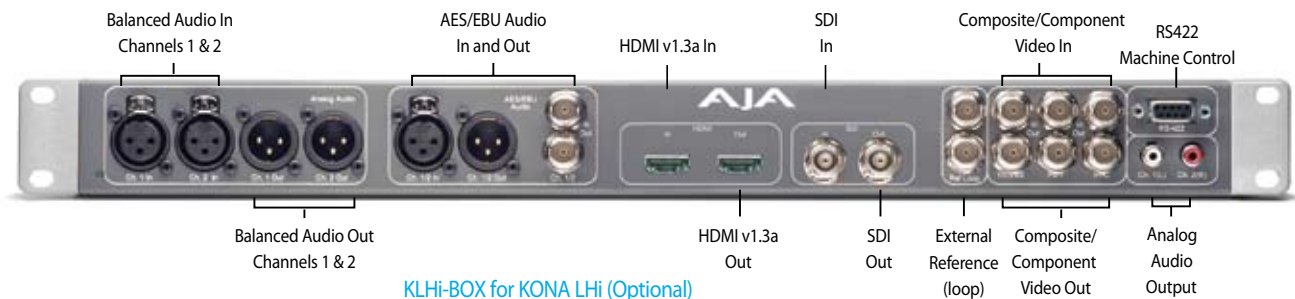

KLHi-BOX for KONA LHi (Optional)

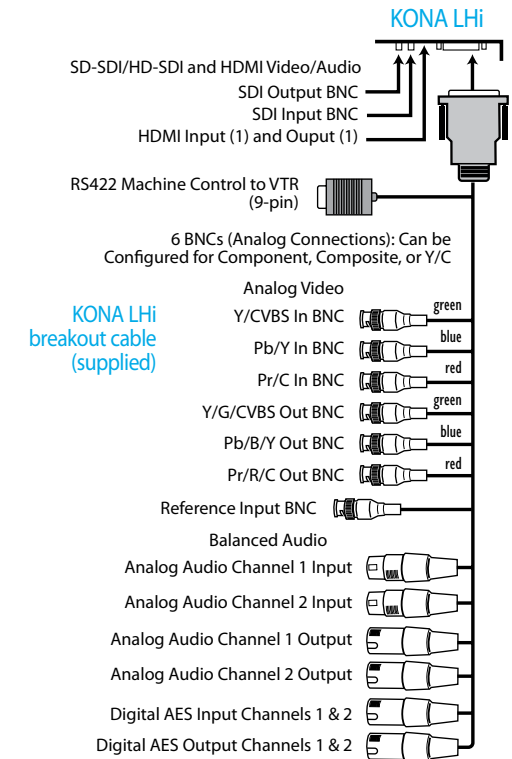

KONA LSe

Analog and Digital capture card for standard definition workflows



The affordably priced KONA LSe is the perfect video capture and playback card for a standard definition editing system on Mac or PC. KONA LSe offers full featured SD connectivity and integration with Apple Final Cut Pro on a Mac, support for software applications like Adobe After Effects and Apple Motion - and can work with a wide range of popular file formats (QuickTime, TGA, TIFF, BMP, AVI, YUV)

KONA LSe can capture to QuickTime™ at uncompressed 10 bit 4:2:2 or 8 bit 4:2:2 and allows ingest from—and mastering to— BetacamSP, Digital Betacam, DVCPRO50 as well as other standard definition VTRs. KONA LSe also supports capture and playback from compressed SD formats like DV and DVCPRO50, to provide the most flexibility for your SD workflows (formats and file type support varies by platform and software used).

KONA LSe also has great audio I/O support: 2-channel balanced XLR analog, 2-channel balanced XLR AES/EBU, and multi-channel embedded SDI audio. Hardware sample-rate conversion is provided on AES inputs, eliminating source synchronizing requirements.

Extend your Connectivity with KL-BOX

The optional KL-Box provides all the standard features of a cable in an easy-to-use 1RU rackmount panel, extending KONA LSe's connectivity with BNC AES/EBU connections, and RCA audio monitoring jacks.



KONA LSe breakout cable (supplied)

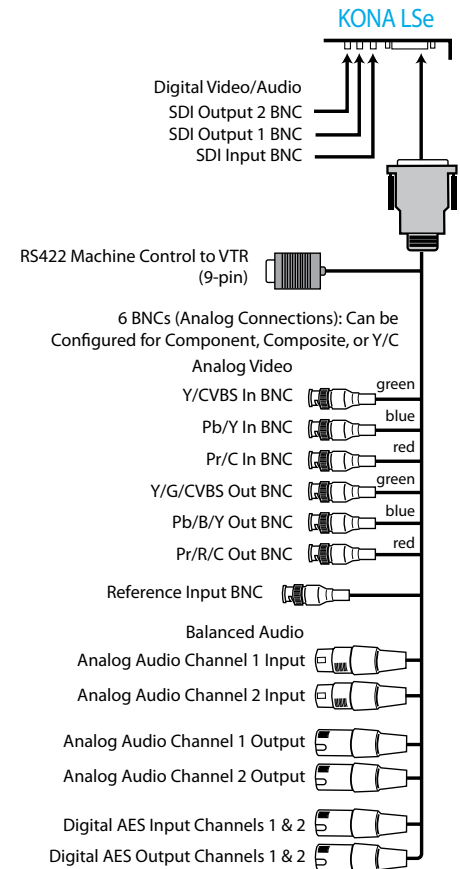

Specifications

KONA3G Specifications

Video Input

Dual-rate (SD or HD)
3Gb SD and HD-SDI, SMPTE-259/292/296/424, 10-bits
Single Link 4:2:2
Dual-link HD 4:4:4
2K HSDL (High Speed Data Link) 4:4:4
1D LUT Support (Mac and PC)

Video Formats

480i 29.97 (PC)
525i 23.98 (intermediate format only)
525i 29.97
625i 25
720P 23.98 (intermediate format only)
720p 24 (PC)
720p 25 (PC)
720p 29.97 (PC)
720p 30 (PC)
720P 50
720P 59.94
720P 60
1080i 25
1080i 29.97
1080i 30
1080PsF 23.98
1080PsF 24
1080PsF 25 (PC)
1080PsF 29.97 (PC)
1080PsF 30 (PC)
1080p 23.98 (PC)
1080P 24
1080P 25
1080P 29.97
1080P 30
1080P 50
1080P 59.94
1080P 60
2048 x 1080P 23.98
2048 x 1080P 24
2048 x 1080PsF 23.98
2048 x 1080PsF 24
2048 x 1556p 15 (PC)
2048 x 1556PsF 14.98
2048 x 1556PsF 15
2048 x 1556psf 23.98
2048 x 1556PsF 24

Video Output

Digital:
3Gb SD and HD-SDI, SMPTE-259/292/296/424
Dual-link HD 4:4:4 and 2K HSDL 4:4:4
HDMI v1.4, 30/36 bits/pixel, RGB or YUV, 2.25Gbps

Analog:

SD and HD Output, 12-bits, BNC
HD: YPbPr, RGB
SD: YPbPr, RGB (component mode) or Composite + Y/C (composite mode with simultaneous Y/C)

Downstream Keyer:

Will output graphics with alpha channel over video, matte or framebuffer, or framebuffer content over incoming video or matte

Audio

24-bit SDI embedded audio,
16 channel, 48kHz
24-bit AES audio, 8 channel w/breakout cable or 16 channel with optional K3G-Box, 96kHz or 48kHz
24- or 16-bit capable

Up-Conversion

Hardware 10-bit

Anamorphic: full-screen

Pillar box 4:3: results in a 4:3 image in center of screen with black sidebars

Zoom 14:9: results in a 4:3 image zoomed slightly to fill a 14:9 image with black side bars

Zoom Letterbox: results in image zoomed to fill full screen

Zoom Wide: results in a combination of zoom and horizontal stretch to fill a 16:9 screen; this setting can introduce a small aspect ratio change

Down-Conversion

Hardware 10-bit

Anamorphic: full-screen

Letterbox: image is reduced with black top and bottom added to image area with the aspect ratio preserved

Crop: image is cropped to fit new screen size

Cross-Conversion

Hardware 10-bit

1080i to 720P

720P to 1080i

720P to 1080PsF

SD to SD Aspect Ratio Conversion

Letterbox: This transforms SD anamorphic material to a letterboxed image.

H Crop: Will produce a horizontally stretched effect on the image; transforms anamorphic SD to full frame

SD Pillarbox: Will produce an image in the center of the screen with black borders on the left and right sides and an anamorphized image in the center

V Crop: Will transform SD letterbox material to an anamorphic image.

Reference Input

Analog Color Black (1V) or Composite Sync (2 or 4V)
Non terminating, Looping, 75 ohm on K3G-Box, terminated on supplied breakout cable

LTC

Input and Output, 2 BNCs

Machine Control

RS-422, Sony 9-pin protocol

KONA LHi Specifications

Video Input

Digital:
3Gb SD and HD-SDI, SMPTE-259/292/296/424, 10-bits
HDMI v1.3

Analog:

Composite/S-Video (Y/C):
NTSC, NTSCJ, PAL 12-bit A/D, 2x oversampling
3 line adaptive comb filter decoding

SD Component:

SMPTE/EBU N10, Betacam 525 line,
Betacam 525J, RGB

12-bit A/D, 2x oversampling

HD Component:

YPbPr

12-bit A/D

1D LUT Support (PC)

Video Formats

525i 29.97
625i 25
720p 23.98 (PC)
720p 24 (PC)
720p 25 (PC)
720p 29.97 (PC)
720p 30 (PC)
720P 50
720P 59.94
720P 60
1080i 25
1080i 29.97
1080i 30
1080PsF 23.98
1080PsF 24
1080PsF 25 (PC)
1080PsF 29.97 (PC)
1080PsF 30 (PC)
1080P 23.98
1080P 24
1080P 25
1080P 29.97
1080P 30
1080P 50
1080P 59.94
1080P 60

Video Output

Digital:

3Gb SD and HD-SDI, SMPTE-259/292/296/424
HDMI v1.3, 30/36 bits/pixel, RGB or YUV, 2.25Gbps,
SD, HD, 1080p50/60

Analog:

Composite/S-Video (Y/C):
NTSC, NTSCJ, PAL
12-bit D/A, 8x oversampling

SD Component:

SMPTE/EBU N10, Betacam 525 line,
Betacam 525J, RGB
12-bit D/A, 8x oversampling

HD Component:

YPbPr, RGB
12-bit D/A, 2x oversampling

Audio

Digital:

24-bit SDI embedded audio,
8 channel, 48kHz
24-bit AES audio, 2 channel, 48kHz
16-bit capable

Analog:

24-bit A/D and D/A, 2 channel balanced
XLR, 48kHz
+24dbu Full Scale Digital
+/- 0.2db 20 to 20kHz frequency response

Up-Conversion

Hardware 10-bit

Anamorphic: full-screen

Pillar box 4:3: results in a 4:3 image in center of screen with black sidebars

Zoom 14:9: results in a 4:3 image zoomed slightly to fill a 14:9 image with black side bars

Zoom Letterbox: results in image zoomed to fill full screen

Zoom Wide: results in a combination of zoom and horizontal stretch to fill a 16:9 screen; this setting can introduce a small aspect ratio change

Down-Conversion

Hardware 10-bit

Anamorphic: full-screen

Letterbox: image is reduced with black top and bottom added to image area with the aspect ratio preserved

Crop: image is cropped to fit new screen size

Cross-Conversion

Hardware 10-bit

1080i to 720P

720P to 1080i

720P to 1080PsF

SD to SD Aspect Ratio Conversion

Letterbox: This transforms SD anamorphic material to a letterboxed image.

H Crop: Will produce a horizontally stretched effect on the image; transforms anamorphic SD to full frame

SD Pillarbox: Will produce an image in the center of the screen with black borders on the left and right sides and an anamorphized image in the center

V Crop: Will transform SD letterbox material to an anamorphic image.

Reference Input

Analog Color Black (1V) or Composite Sync (2 or 4V)
Non terminating, Looping, 75 ohm on KLHI-Box,
terminated on supplied breakout cable, BNC assignable as LTC input or Reference Input

Machine Control

RS-422, Sony 9-pin protocol

KONA LSe Specifications

Video Input

SD-SDI SMPTE-259

Composite/S-Video (Y/C):

NTSC, NTSCJ, PAL
12-bit A/D, 2x oversampling
3 line adaptive comb filter decoding

Component:

SMPTE/EBU N10,
Betacam 525 line, Betacam 525J, RGB
12-bit A/D, 2x oversampling

Video Formats

525i 29.97, 625i 25

Video Output

Digital:

SD-SDI, SMPTE, 259M, 10-bits, BNC

Analog:

Composite/S-Video (Y/C):
NTSC, NTSCJ, PAL 12-bit D/A, 8x oversampling

Component:

SMPTE/EBU N10, Betacam 525 line,
Betacam 525J, RGB
12-bit D/A, 8x oversampling

Audio

Digital:

24-bit SDI embedded audio, 8 channel, 48kHz
24-bit AES audio, 2 channel, 48kHz
16-bit capable

Analog:

24-bit A/D and D/A, 2 channel balanced XLR, 48kHz
+24dbu Full Scale Digital
+/- 0.2db 20 to 20kHz frequency response

Reference Input

Color Black
(Ref input is looping, non-terminating on the KL-Box
Breakout Box;
terminated on supplied breakout cable)

Machine Control

RS-422, Sony 9-pin protocol

Incredible 3 Year Warranty

AJA Video warrants that KONA products will be free from defects in materials and workmanship for a period of three years from the date of purchase.

About AJA Video Systems, Inc.

Since 1993, AJA Video has been a leading manufacturer of video interface and conversion solutions, bringing high-quality, cost-effective digital video products to the professional broadcast and post-production markets. AJA offers the Io and KONA desktop video products, Ki Pro family of recorders, miniature stand-alone converters, and a complete line of rack mount interface and conversion cards and frames. With a headquarters and design center located in Grass Valley, California, AJA Video offers its products through an extensive sales channel of dealers and systems integrators around the world. For further information, please see our website at www.aja.com

B e c a u s e i t m a t t e r s .



AJA Video Systems Inc.

Grass Valley, California

www.aja.com • sales@aja.com • support@aja.com