

SI1015-8000 Single System Package

Wireless | Systems

System Includes:

- (1) SI1015—Two channel modulator
- (1) NT1015-120—29 V DC power supply
- (1) GA1031-CC—Rack adapter for SI1015 modulator
- (2) SZI1015—Emitter panel for single, dual or multi channel use
- (2) WM1—Wall/ceiling mount
- (1) SZA1060—Terminating resistor
- (10) RI250—Single channel infrared stethophone receiver
- (1) L151-10/NT—Charging unit with power supply
- (1) NT92-120—AC adapter for L151-10 charging unit

General Description

Sennheiser offers system packages that include all components necessary to configure a complete system. Sennheiser's Large-Area Infrared Systems provide coverage of 4,000 sq. ft. up to 12,500 sq. ft. in both single and dual channel modes. The SI1015 modulator and SZI1015 or SZI1029 emitters are the primary components of the systems. The NT1015-120 will provide power for the SI1015 modulator and up to two SZI1015 or SZI1029 emitters. The SZA1060 terminating resistor (50 ohm), for the last emitter in a daisy chain, is included for system designs that incorporate daisy chaining of emitters. The GA1031-CC rack adapter allows for easy mounting of a SI1015 modulator to a 19" rack. The WM1 wall/ceiling mount easily mounts the SZI1015 or SZI1029 emitter panels. The RI250 stethophone infrared receivers are for use with single channel systems operating at 2.3 MHz, and include the BA151 rechargeable battery. Alternatively, for dual channel systems, the HDI302 stethophone infrared receiver is for use with systems operating at 2.3/2.8 MHz, and also includes the BA151 rechargeable battery. The BA151 rechargeable batteries can be conveniently recharged with the L151-10 charging unit(s) with the NT92-120 power supply. In addition, the NT2013-120 will power two to five L151-10 charging units.

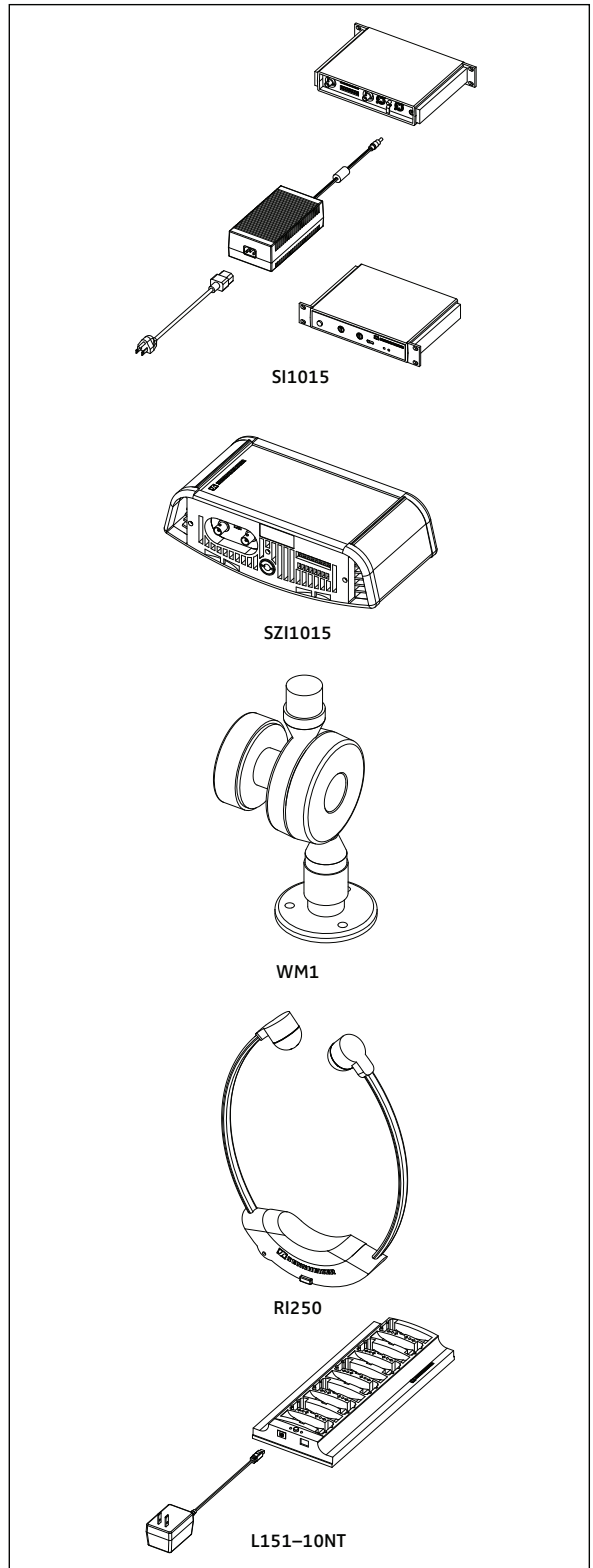

SI1015

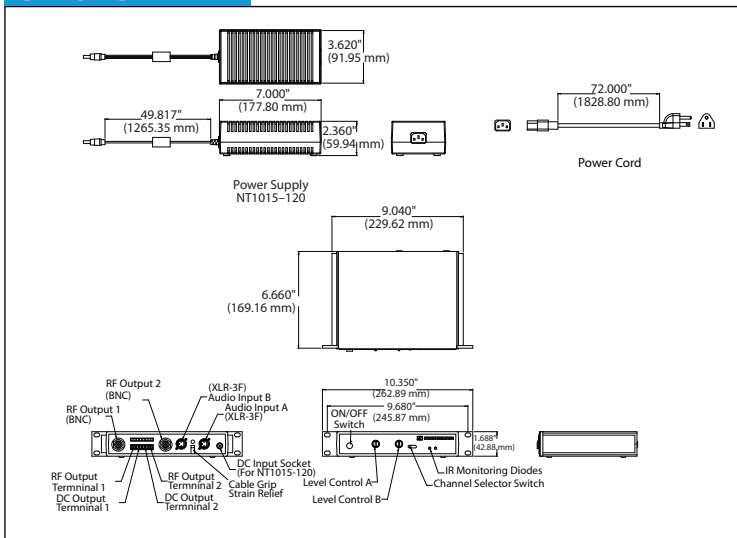

SI1015—Rack mountable, half rack, two channel modulator. Operates at 2.3/2.8 MHz. NT1015-120 power supply required.

* Illustrations do not show NT1015-120 power supply, GA1031-CC rack adapter, NT92-120 adapter, SZA1060 terminating resistor

SI1015-8000 Single System Package

SZI1015-NT

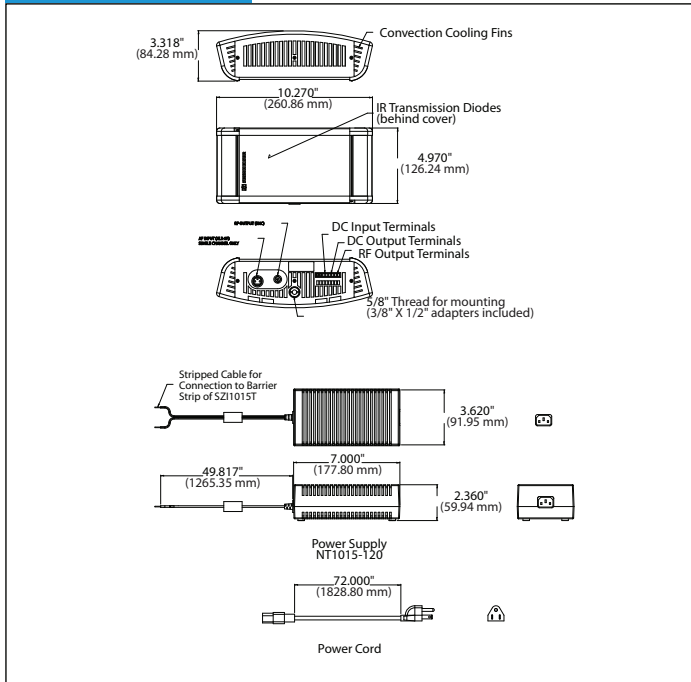

ESZI1015-NT—Emitter panel for single, dual or multi channel use. Coverage: up to 4,000 sq. ft. in single channel mode. (3 lbs)

RI250

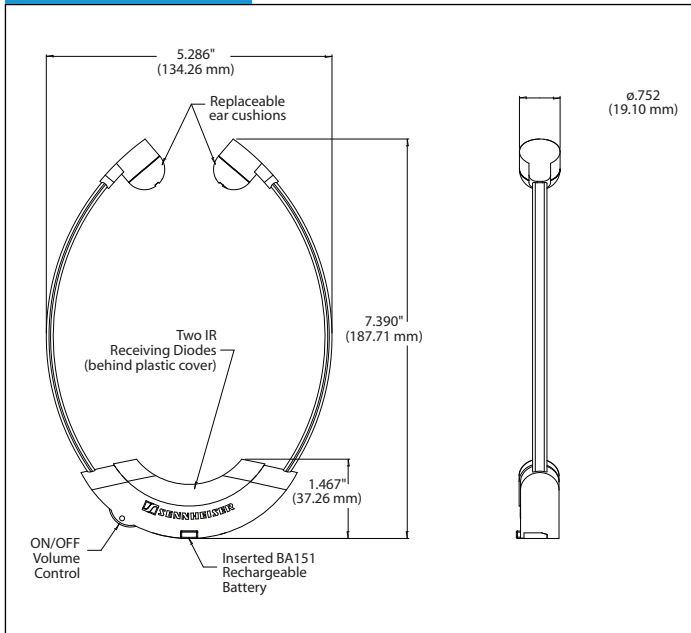

RI250—Single channel infrared stethophone receiver for use with infrared systems operating at 2.3 MHz. Includes one BA151 rechargeable battery. (1.6 oz)

WM1

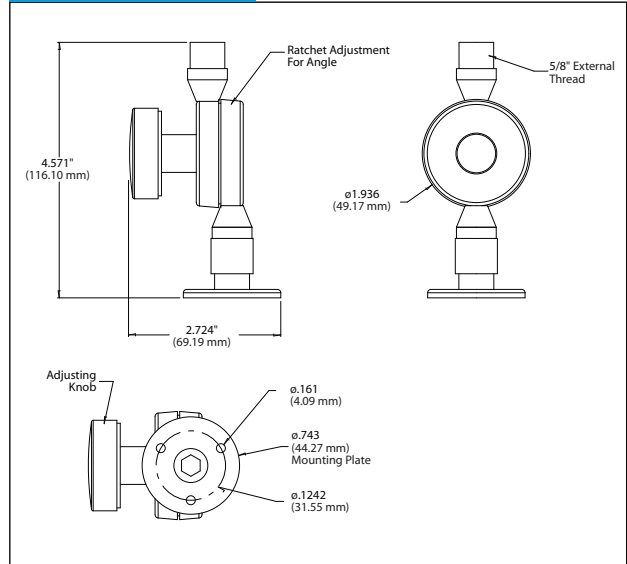

WM1—Wall/ceiling mount with 5/8" thread for mounting 2 or more SI30 or SZI30.

L151-10NT

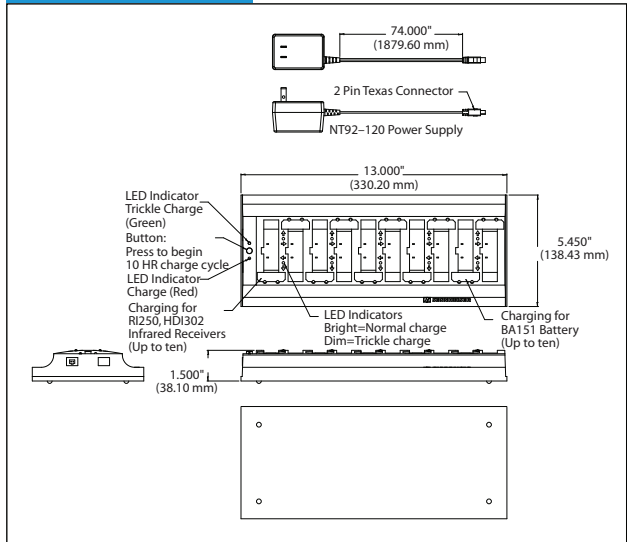

L151-10/NT—Charging unit with power supply that charges either 10 BA151 rechargeable batteries or 10 RI250 infrared receivers

SI1015-8000 Single System Package

Architects Specifications

SI1015-8000 Single

The infrared system shall be modular and provide coverage for up to 8,000 square feet in single channel mode.

The SI1015 modulator must utilize the higher sub-carrier frequencies of 2.3 and 2.8 MHz for single, two channel or stereo operation with an AF frequency response of 50-15,000 Hz. It must be rack-mountable and have two monitoring diodes for the technician. It must accept line level audio input via XLR connector. It must be easy to install using barrier strip with RF and DC outputs for connecting to emitters; and, alternatively, BNC connectors for connecting the RF signal only. It must have AF level controls with LED's indicating peak volumes. The modulator must be capable of remotely powering one or two emitters.

The power supply NT1015-120 shall provide power for one SI1015 emitter and up to two SZI1015, and shall have an input voltage of 100-240 V (1.3 A), an output voltage of approx. 29 V and an output current of 1.7 A.

The GA 1031-CC rack adapter is capable of mounting an individual SI 1015 modulator to a 19" rack.

The SZI1015 emitters shall be wall or ceiling mountable via a mounting clamp with 5/8" external male thread, and the mounting plate shall have a diameter of 1 5/8".

The single-channel infrared receivers shall be stethoset design with a carrier frequency of 2.3 MHz. The AF frequency response must be 18-18,000 Hz. The receivers shall contain a rechargeable Nickel Metal Hydride battery, which can easily be recharged with the L151-10/NT charging device (with power supply) for up to ten rechargeable batteries.

The SZI1015 shall be an infrared emitter with a carrier frequency band that extends to 6 MHz RF input (50 mV to 3V) via BNC socket or barrier strip, RF output via BNC socket or barrier strip. The unit shall offer excellent reliability due to 72 individual diodes. The unit shall offer an operating voltage of 25-30 V DC and weigh approx. 3 lbs. The unit shall be a Sennheiser SZI1015. Coverage: 4,000 sq. ft. in single channel mode (per emitter).

The SZA1060 shall weigh 1.0 oz and be a 50 ohm terminating resistor for the last emitter in a daisy chain.

Limited Product Warranty/Service

Sennheiser Electronic Corporation extends the following limited product warranty for Sennheiser products:

The warranty period for all covered Sennheiser products is two years from the date of purchase. Not covered by this warranty are accessories and other consumables; for example, items of wear and tear, such as cables. During the warranty period, Sennheiser Electronic Corporation warrants that the Sennheiser equipment will be free from defects in materials and workmanship used in making the product. Abnormal conditions, deliberate abuse and damage due to accidents, operator's error, or unauthorized service attempts are excluded from any warranty claims.

Under this warranty, Sennheiser Electronic Corporation will repair, or at its option, replace free of charge the covered defective Sennheiser product, provided it is returned (postage paid, with proof of purchase from the original seller) to a Sennheiser Service Facility. Products should be returned in their original package, or otherwise suitably protected to avoid shipping damage. Either product registration or a valid, dated proof of purchase is accepted to establish the warranty period. The Sennheiser Service Department will be the sole authority to determine the validity of all warranty issues.

This Limited Product Warranty is Sennheiser Electronic Corporation's only warranty, and the customer's only remedy concerning Sennheiser products. All other representations and warranties, express or implied, written or oral, including, but not limited to, any warranties of merchantability, fitness for a particular purpose, or non-infringement, are expressly excluded. As a result, except as set forth in the previous paragraphs, the product is sold "as-is" and the customer is assuming the entire risk as to the product's suitability for his needs, its quality and its performance.

In no event will Sennheiser Electronic Corporation be liable for direct, indirect, special, incidental or consequential damages resulting from any defect in the product or from its use, even if advised of the possibility of such damages.