



General Description

The Rane AM 2 is both an 8 channel, gain-sharing automatic mic mixer and simultaneously a Rane RAD. Use it as a standalone mic-only mixer, add more gain-shared mics using up to seven additional AM 2 Automixers, and/or use the RAD Port to transport the mic mix via a Rane Mongoose to a CobraNet network. If you need manually mixed line audio sources, including USB Audio I/O, see the Rane AM 1 Automixer.

Each of the eight XLR Mic Inputs offers front panel input Level controls feeding a gain-sharing automatic mixer. Rear panel, 3-position selectors support dynamic mics (no phantom power), condenser mics (48 V), or line input optimized for wireless receiver outputs (+10 dBu max). All Level controls come with front panel signal and overload indicators.

The AM 2 is optimized for automixing speech. The mic inputs have a fixed 100 Hz to 7 kHz bandpass filter to provide the best voice-only automatic mixing using the gain-sharing algorithm.

The XLR Main Output can be set to mic- or line-level to feed a mic snake or a +20 dBu max balanced input. When an AM 2 is used standalone, both the XLR Output and the RAD Port output audio are affected by the front panel Output Level control. When the AM 2's Cascade Output feeds a downstream Rane AM 1 or AM 2, the front panel Output Level control only affects the XLR Output.

The USB port is solely used as a firmware update port if future updates are needed.

The RAD Port sends the AM 2 Output mix to a Rane Mongoose for routing to output RADs and/or a CobraNet network. Cascade IN accepts audio and data from an upstream AM 2's Cascade OUT. This adds eight more mic channels to the initial AM 2 creating a 16-channel gain-sharing automix. A maximum

of eight AM 2s can be cascaded, offering up to 64 gain-shared mics. If an AM 1 is included, it must be the final device in the chain of no more than eight. Simply connect Cascade OUT ports to Cascade IN ports and the AM 1 RAD Port to the Mongoose. Both the Cascade IN port and the Cascade OUT/RAD Port have status indicators to aid setup and troubleshooting.

Rear panel Fault, Locate, USB and Power indicators inform head-scratchers of device errors, the AM 2's physical location, positive USB audio device OS registration and AC power status.

Duplicate Locate and Power indicators on the front help installers physically locate and verify AC power to the AM 2.

Universal IEC power on the rear supports 100 to 240 VAC and 50/60 Hz.

Features

INPUTS:

- Gain-Sharing Automatic Mic Mixing:
 - 8 XLR Inputs with Level controls & Sig/OL indicators.
 - Select Mic, Mic with 48V phantom, or Line level.

OUTPUT:

- XLR Main with Mic/Line switch, Level control & Sig/OL.
- Rane RAD and Cascade IN RJ-45 Ports:
 - RAD Port sends Output to Mongoose for CobraNet transport.
 - Cascade IN connects up to seven more Rane AM 2 Automixers.

Rear Panel





Features and Specifications	
XLR Inputs	Mono, Balanced, Mic/Line Selectable
Phantom Power	+48V per IEC 60268-15, Selectable in Mic mode
Maximum Input (Mic/Line)	-17 / +10 dBu
Input Impedance	2.01k, 1%
Input Gain Range (Mic/Line)	-80 to +34 dB / -80 to +26 dB
Frequency Response	100 Hz to 7 kHz, +0/-3 dB, -20 dBFS, Extended vocal range
Main Output	Mono, Balanced, XLR
Maximum Output (Mic/Line)	-20 / +20 dBu, 10 kΩ load
Output Impedance (Mic/Line)	51 / 300 Ω, 1%
Output Gain Range	-80 to 0 dB
Frequency Response	100 Hz to 7 kHz, +0/-3 dB, -20 dBFS
Dynamic Range	101 dB re +20 dBu, 20 kHz BW, A-weighted, 0 dB gain, 10 kΩ load
THD+N	< 0.02%, 100 Hz to 7 kHz, A-weighted, +4 dBu, 0 dB gain, 10 kΩ load
LED Meters	Mono, peak detecting
Signal	-50 dBFS, Green LED, Peak-Reading
Overload	-0.5 dBFS, Red LED, Peak-Reading
RAD / Cascade In / Out	8P8C (RJ-45) Connector
Sample Rate and Resolution	48 kHz @ 24 bits
Unit	All Steel Construction
Universal Line Voltage	100 to 240 VAC, 50/60 Hz, 13 W
Agency Listing	UL/cUL/CE
Size	1U 1.75"H x 19"W x 8.5"D (4.4 cm x 48.3 cm x 21.6 cm)
Weight	5 lb 4 oz (2.4 kg)
Shipping Size	4.5" x 20.3" x 13.75" (11.5 cm x 52 cm x 35 cm)
Shipping Weight	9 lb (4.1 kg)
<i>Note: 0 dBu = 0.775 Vrms</i>	

Architectural Specifications

The 1U audio device shall provide 8 rear-mounted XLR inputs automatically mixed using a gain-sharing algorithm. Each input shall permit selectable mic, mic with 48 volt phantom power, or line input level intended for wireless receiver outputs. Front panel mic input level controls for each input shall indicate signal and overload and an overall output level control with signal and overload shall be provided.

When used standalone without cascading addition mics, accommodation for two, post-level audio outputs shall be provided. One on a single XLR male balanced analog output with mic/line selector switch and the second via a Rane RAD Port on RJ-45 providing 24-bit, 48 kHz PCM digital audio transport to

a CobraNet network via a Rane Mongoose. When cascading additional gain-shared mics downstream, the front panel output level control only affects the XLR Output.

A USB Data port shall be provided to support firmware updates should they be needed.

A cascade input RJ-45 shall permit gain-sharing mic mix expansion in groups of 8 channels from external automixer devices. Up to 64 gain-shared mics with a maximum of eight 1U devices shall be supported. To input line audio sources or perform headphone cueing, a Rane AM 1 is supported.

Universal 100 to 240 volt AC, 50 or 60 Hz operation shall be provided on an IEC rear panel plug.

The unit shall be a Rane AM 2.

Block Diagram

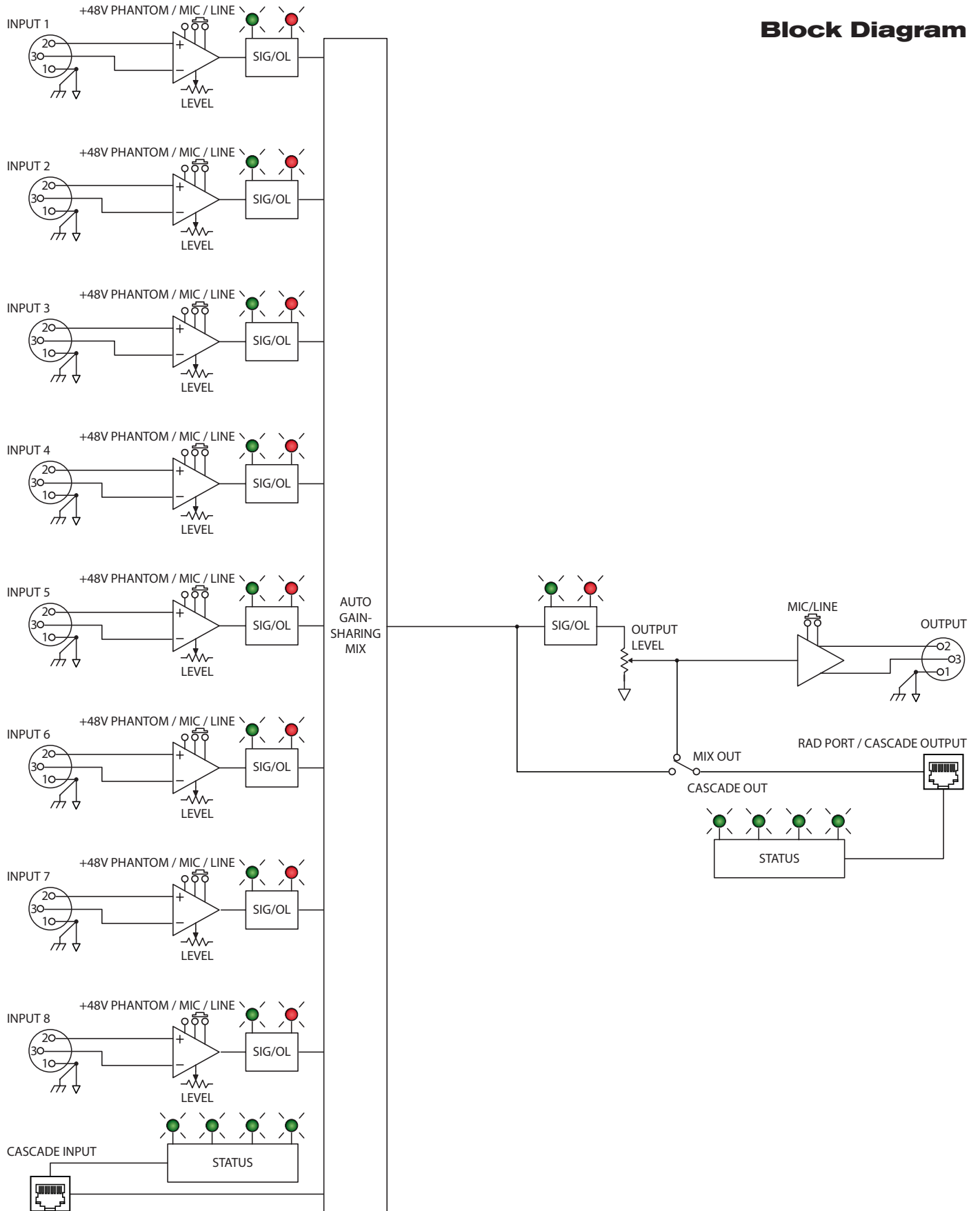

Applications

Facilities and rental agencies are called upon to provide either equipment, or equipment and operators, for meetings or conferences needing A/V support. The equipment providers must ensure audio quality throughout the event to get repeat business. However, the provided equipment may be operated by presenters who have no audio experience. If an operator is sent with the equipment to set up and manage the system during the presentation, that operator may have minimal audio experience. Pitfalls abound when interconnecting the system, and managing multi-microphone gain before feedback, mixing and volume. Enter the Rane AM 2.

The AM 2 makes it easy for an inexperienced operator to quickly set up and manage multiple microphones for presentations involving up to eight participants with wired or wireless microphones. When cascading the AM 2 with the Rane AM 1 (sold separately), support for several program audio sources (e.g., DVD, laptop, MP3 player) is easily added.

The AM 2 offers a professional integrated solution providing superior automatic gain before feedback while eliminating operator error with its simple controls. The microphone gain-sharing algorithm automatically and appropriately attenuates mics not in use while maintaining the 3 dB per doubling of mics for different talkers (noncoherent signals), and 6 dB per doubling for the same talker who is directly between two mics (coherent signals).

