

## UADC-1

### Utility Analog Digital Converter / Switch

The ATI UADC-1 Utility Analog-Digital Converter gives you professional quality 24-bit A-to-D conversion, along with seamless AES audio path insertion and interruption functions. The UADC-1 may be used as a standalone high quality A/D converter or to interrupt an AES stream and insert an analog input via remote control, making it a perfect companion for analog EAS encoders / decoders.

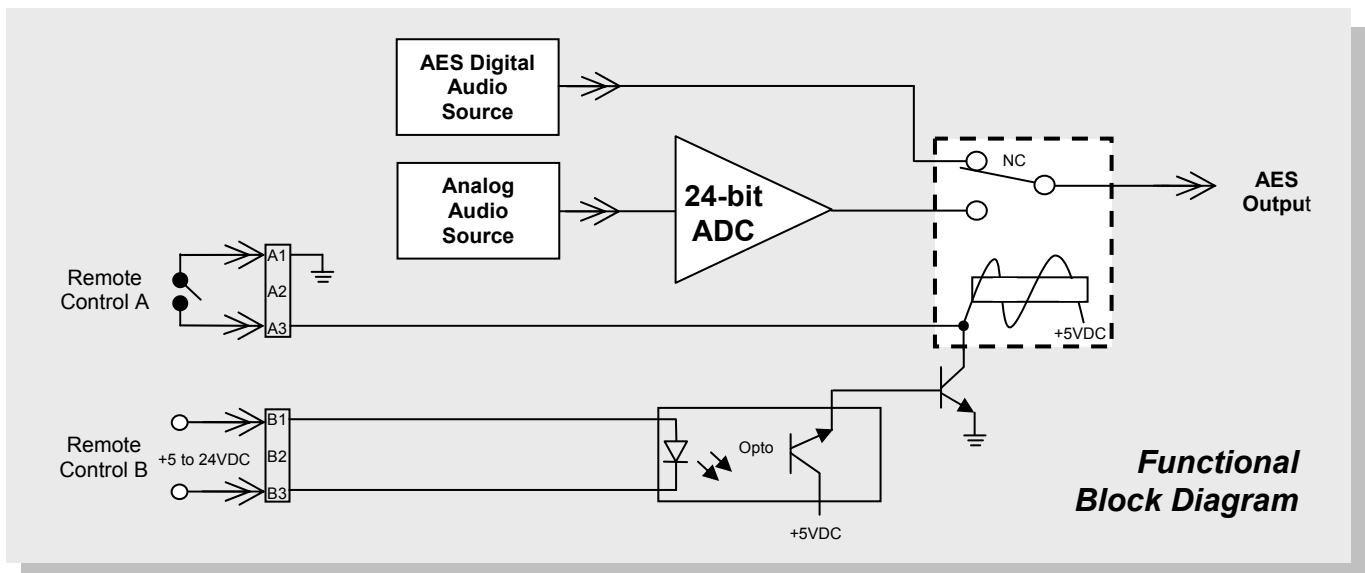

#### Product Features

- **Balanced and Unbalanced Stereo Analog Inputs**
- **AES Input - AES Output**
- **High Performance 108dB Noise Floor**
- **Seamless Remote Control**  
Dry : Contact Closure or  
Wet : 5 – 24VDC
- **UL approved +24VDC External Power Supply**

The UADC-1 is equipped for failsafe operation with relay bypass if power is lost. The A/D converter is shipped to provide broadcast standard 44.1kHz sample rates, with 32kHz or 48kHz sampling selectable via internal jumpers.



## Specifications

Analog Input Level	-10dBu to +24dBu +4dBu analog input provides -20dBfs AES output
Analog Input Impedance	10KΩ balanced
Frequency Response	10 – 20kHz, +/-0.5dB
Distortion	<.01% THD / IMD
Noise	<108dB EIN
AES Output Impedance	110Ω, balanced from analog / A-D input; passive when AES input is active
Power Requirements	24VDC, 600mA, wall transformer, supplied
Size	1/2 rack space
Weight	6.0 lbs (2.7kg)

## Connections / Options

L/R Analog Inputs	Hi-Z, active balanced on XLR connectors. Unbalanced analog on L and R terminals of the plug-in Euroblock connector; G is for unbalanced shield.
AES Input	Main AES source input on XLR.
AES Output	AES output on XLR has either AES input audio or A-D derived AES output from L/R analog input.
Remote Control	Operates from a Dry external contact closure or Wet via an opto-isolated 5 – 24VDC input (6mA at 5VDC).
Options	21071-501 Rack Mounting Shelf 21098-501 1/2 RU Blank Panel 220VAC 50-60Hz CE-approved External Power Supply

