

PMP980S/PMP960M

6/10 x 2 Live Powered Mixers

PMP980S: Ultra-compact 2 x 450-Watt stereo powered mixer

PMP960M: Ultra-compact 2 x 450-Watt dual mono powered mixer

Revolutionary amplifier technology: enormous power, incredible sonic performance and super-light weight

PMP980S: 10-channel mixer section features 6 mono channels and 2 stereo channels plus separate tape returns

PMP960M: 6 mono channels plus separate tape returns

PMP980S: 2 studio-grade 24-bit stereo FX processors with 100 awesome presets

PMP960M: 1 studio-grade 24-bit stereo FX processor with 100 awesome presets

FBQ Feedback Detection system instantly reveals critical frequencies for easy feedback removal

8/6 high-quality mic preamps with switchable +48 V phantom power for condenser microphones

Effective, extremely musical 3-band EQ, switchable Pad and Clip LEDs on all mono channels

Stereo 7-band graphic EQ allows precise frequency correction of monitor and main outputs

Speaker Processing function adjusts frequency response to match professional speaker systems like BEHRINGER EUROLIVE series

Powered Mixers

EUROPOWER — 900-Watt 10-Channel/6-Channel Mixer with FX



If you need superior sound quality for small club gigs, churches or speeches, but have to keep the outboard gear to a minimum, get ready to love the PMP980S and PMP960M. The 900-Watt, 10-channel/6-channel mixers give you everything you need in one efficient, highly portable little package.

Massive mono or stunning stereo

The difference between these two mixers is that the PMP980S gives you two stereo channels. If you make your beer money playing in a bluegrass

band at a barbecue joint, you probably aren't that interested in making a space-age, multi-dimensional mix. This is just one example of where the PMP960M's six mono channels would be a perfect match.

However, if you're the brains behind a kraut-rock band with the wildest patches this side of Berlin, the two additional stereo channels on the PMP980S will provide the sonic latitude you need.

The PMP980S is also an excellent choice for a church, where vocals and stereo recordings share face time.

Continued on next page

behringer.com



PMP980S/PMP960M

6/10 x 2 Live Powered Mixers



Loudspeaker (monitor mix)

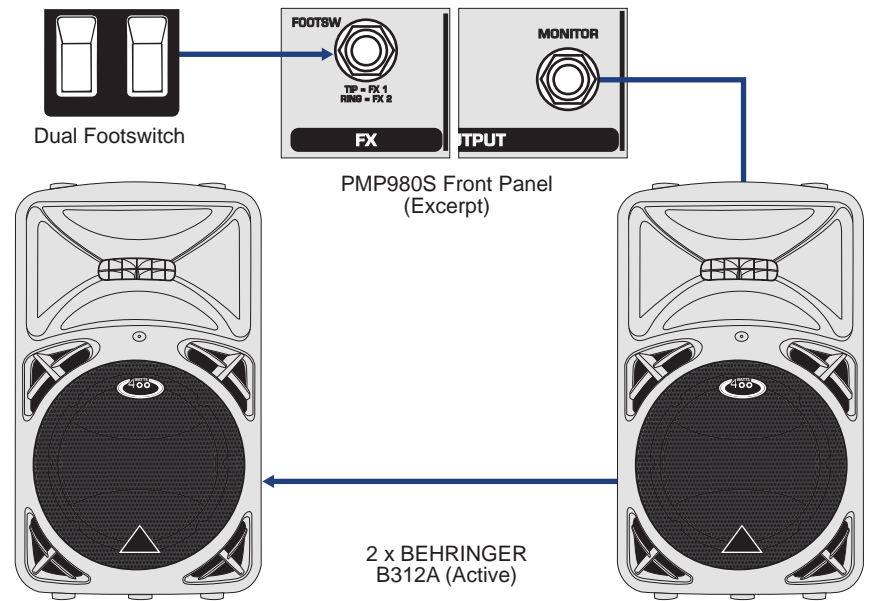

Classic control, state-of-the-art sound

Each of the mic inputs on the PMP980S and PMP960M contains top-quality built-in mic preamps with switchable +48V phantom power for condenser mics—just like in our studio mixers. Suddenly you can leave the mic preamps at home, and the kind of sound quality that was once only available in the studio is ready to go wherever you do.

Plus with the built-in 24-bit FX processor, you get 100 mind-blowing digital effect presets such as delay, chorus and reverb you can apply to any channel, as well as to the monitors and main output. No outboard gear needed — and the PMP980S comes with dual FX processors for double the effects!

These mixers come loaded with BEHRINGER's amazing FBQ feedback detection system, which automatically pinpoints trouble frequencies so you can snuff them out before you—or the audience—go deaf. Just touch a button and watch as trouble frequencies are indicated by red LEDs on the 7-band graphic EQ.

The Ins and Outs

The PMP980S and PMP960M give you loads of flexibility in accommodating whatever the center of attention happens to be. Channels 1-6 of both mixers are for mics, bass guitars or other mono instruments. The PMP980S features channels 7-8 and 9-10, which can be used as stereo channels. In the case of the PMP980S, that means you can connect up to 8 microphones or other mono instruments or six

mics or mono instruments along with two stereo instruments (keyboards, for example) or the A/V equivalent.

In the bottom right corner of the mixer, you'll find the FX, INPUT TO MAIN and OUTPUT sections. The FX section features a FOOTSW(itch) input. This lets you connect a footswitch like the AB200 so you can remotely enable/disable either FX channel. FX OUT 1 & 2 are used to connect up to two outboard effects processors.

The AUX IN ¼" inputs in the INPUT TO MAIN section allow you to route an external stereo signal to the main mix. The AUX IN control adjusts the volume of the external signal in the main mix. Use the 2TR IN RCA inputs to feed in external stereo signals from CD players or tape decks. The VOICE CANCELLER switch allows you to eliminate the vocals from pre-recorded music for karaoke applications.

In the OUTPUT section, the REC OUT RCA outputs send line-level signals from the mixer to a recording device, so you can finally get to work on that triple-live album you've always dreamed of. The MAIN ¼" connectors are there just in case you want to connect more amps. Connect your monitor power amps or active monitor speakers to the MONITOR output.

Channel your inner sound guru

You'll be operating this mixer like it's second nature thanks to its simple, intuitive layout. Each channel has a three-band EQ (HIGH, MID, LOW) blue; MON(itor) level in gray; FX1 in red; FX2 in orange (PMP980S only); PAN in black (only PMP980S); LEVEL in white. There's also a switchable PAD and CLIP LED per channel.

Once you've set the levels on individual channels, it's easy to create your MAIN and MONITOR mixers. The MAIN and MONITOR sections are nearly identical, featuring graphic 7-band EQs that allow you to adjust the sound to the room acoustics.

This is where the FBQ feature comes in particularly handy. Press the FBQ IN switch to activate the Feedback Detection System. Trouble frequencies are indicated by brightly lit fader LEDs. Just lower the level of the respective frequency range until feedback disappears and the LED goes out.

The FX RET controls add the selected effect signal to the main or monitor mix. When both are completely counterclockwise, no effect is applied. The 2TR IN control adjusts the volume of the 2 Track signal, if you have connected one.

Continued on next page

PMP980S/PMP960M

6/10 x 2 Live Powered Mixers

Use the MAIN MASTER/MONITOR MASTER controls to adjust the main and monitor output signals, respectively. The 5-digit LED meters give you a visual representation of these volumes. The upper LIM LED illuminates when output levels are too high, activating the internal amp protection circuit.

PMP980S's POWER AMP switch toggles between three operating modes: STEREO, MON/MONO and BRIDGE (the power outputs of A and B on the back panel are added and provided at OUTPUT B). The PMP960M provides similar options: Bridge mono or dual mono (Output A can be used for mono Mains and Output B for Monitor Send 1, or Outputs A and B can be used as Main/Main). This clever functionality enables you to power both your mains and monitors without the need for an additional power amp just for your monitors.

Directly below, you'll find the SPEAKER PROCESSING switch that activates a filter in both models, adapting the mixer to the frequency response of your loudspeakers.

Finally, the STANDBY switch lets you mute all input channels during breaks, preventing the microphones from picking up noise or interference. You can leave all faders untouched while you play a CD via the CD/TAPE inputs.

Small, simple, superb

Small, simple events call for a lightweight, simple powered mixer, and these are the most efficient, affordable mixers for the job. They're easy to learn, easy to operate, and with so many incredible built-in features, they make it easy to put on a show in an instant.



Front Panel

EUROPOWER PMP980S

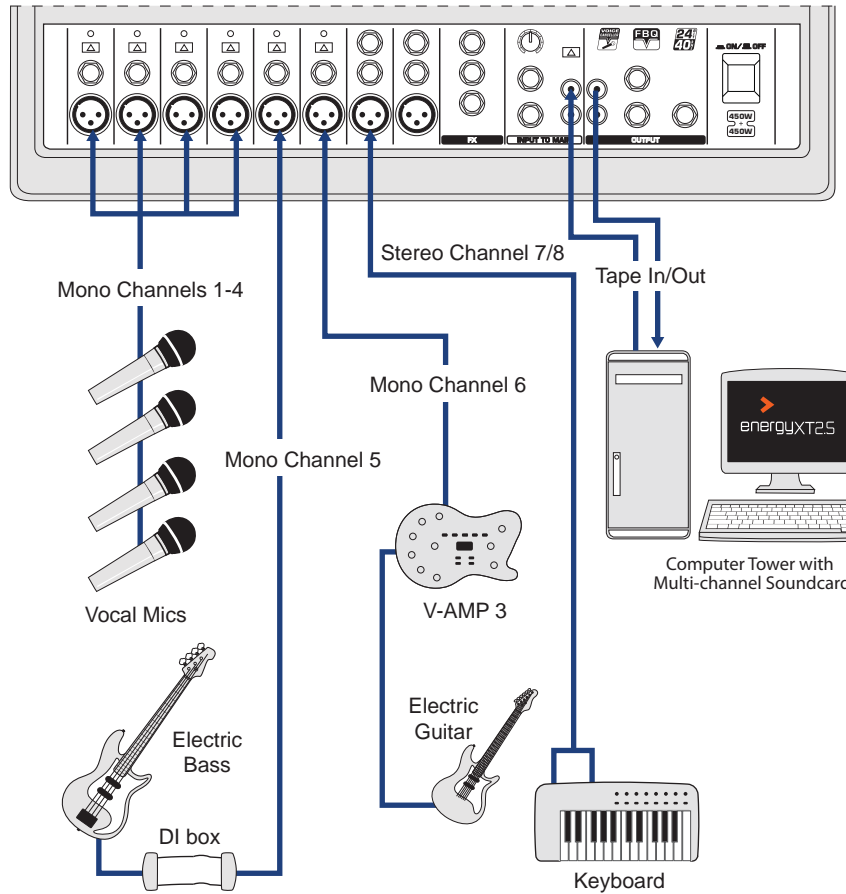

energyXT2.5
DAW software
available separately

Loudspeaker (F.O.H. mix)

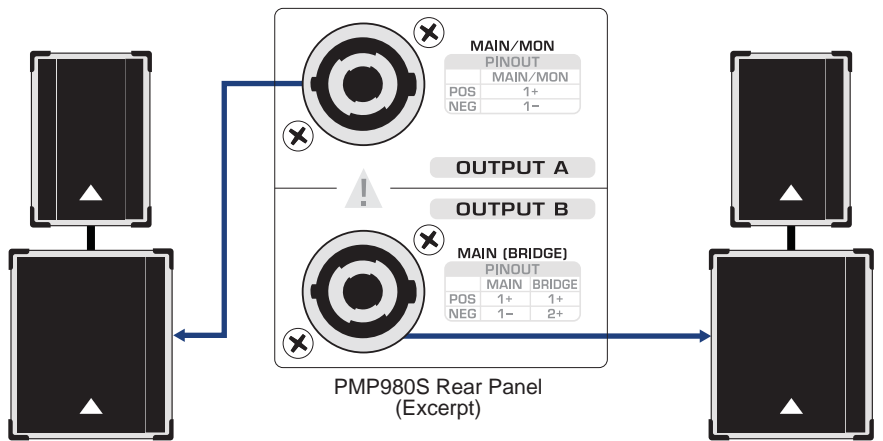

2 x BEHRINGER EUROLIVE Stack (VP1800S & B212XL, both passive)

PMP980S/PMP960M

6/10 x 2 Live Powered Mixers

PROGRAM dial selects FX presets.

FX adjust effects return level in main signal.

FX adjust effects return level in monitor.

7-band graphic EQ

FX IN switch activates FX processor.

HIGH EQ.

MID EQ.

LOW EQ.

MON adjusts signal level to monitors.

FX 1 controls level of signal to FX 1.

FX 2 controls level of signal to FX 2 (PMP980S only).

PAN adjusts channel signal in stereo image (PMP980S only).

Channel signal LEVEL control.

CLIP LED.

PAD switch reduces input sensitivity by 20 dB.

1/4" bal/unbal input.

8/6 MONO channels, bal XLR IN.

Left and right bal/unbal line level 1/4" TRS inputs for stereo channels (PMP980S only).

FX OUT 1&2 1/4" jacks connect to outboard equipment (PMP960M has a single FX OUT).

FOOTSW(itch) input.

AUX IN dial adjusts external signal level in main mix.

AUX IN 1/4" inputs route external stereo signal to main mix (PMP960M has only one AUX IN).

FBQ switch

CD/TAPE IN adjusts CD/TAPE signal in monitor.

4-segment MONITOR LEVEL meter.

OUTPUT A & B connect to PA speakers.

PHANTOM switch for using condenser mics.

MONITOR MASTER dial controls monitor signal volume.

POWER AMP switch toggles between STEREO, MONO and BRIDGED mode.

4-segment MAIN LEVEL meter.

SPEAKER PROCESSING switch activates filter, adapting mixer to loudspeakers.

MAIN MASTER dial control main signal volume.

STANDBY switch mutes all input channels.

VOICE CANCELER switch eliminates vocals from CD/TAPE IN signal.

MAIN 1/4" jacks send signal to external amplifier.

1/4" MONITOR output connects to power amplifiers or active monitor speakers.

RCA CD/TAPE IN and REC OUT jacks.

PMP980S/PMP960M

6/10 x 2 Live Powered Mixers

SPECIFICATIONS

PMP980S

MICROPHONE INPUTS

Type	XLR, electronically balanced input circuit
Mic E.I.N. (20 Hz - 20 kHz)	-
@ 0 Ohm source resistance	-112 dB / 114 dB A-weighted
@ 50 Ohm source resistance	-112 dB / 114 dB A-weighted
@ 150 Ohm source resistance	-112 dB / 114 dB A-weighted
Frequency response	< 10 Hz - 200 kHz (-1 dB) < 10 Hz - > 200 kHz (-3 dB)
Gain	+12 dBu @ +10 dB gain
Max. input level	+12 dBu @ +10 dB gain
Impedance	approx. 2.2 kΩ balanced / 1.1 kΩ unbalanced
Signal-to-noise ratio	110 dB / 114 dB A-weighted (0 dBu In @ +10 dB gain)
Noise (THD + N)	0.001% / 0.0007% A-weighted

MONO LINE INPUTS

Type	¼" TS connectors, balanced
Impedance	approx. 20 kΩ, balanced
Max. input level	+21 dBu

STEREO LINE INPUTS

Type	¼" TRS connectors, unbalanced
Impedance	approx. 100 kΩ, unbalanced
Max. input level	+21 dBu

EQUALIZER

Low	80 Hz / ±15 dB
Mid	2.5 kHz / ±15 dB
High	12 kHz / ±15 dB

2 TRACK INPUT

Type	RCA
Impedance	approx. 10 kΩ

PREAMP OUTPUTS

MAIN	
Type	¼" TS connectors, unbalanced
Impedance	approx. 150 Ω, unbalanced
Max. output level	+21 dBu
MONITOR	
Type	¼" TS connectors, unbalanced
Impedance	approx. 150 Ω, unbalanced
Max. output level	+21 dBu

STEREO OUTPUTS

Type	¼" TRS connectors, unbalanced
Impedance	approx. 150 Ω, unbalanced

Max. input level	+21 dBu
Type	RCA
Impedance	approx. 1 kΩ
Max. input level	+21 dBu

MAIN MIX SYSTEM DATA

Noise:	
MAIN MIX @ -∞	-102 dB / -106 dB A-weighted
Channel fader -∞	-102 dB / -106 dB A-weighted
MAIN MIX @ 0 dB	-88 dB / -91 dB A-weighted
Channel fader -∞	-88 dB / -91 dB A-weighted
MAIN MIX @ 0 dB	-84 dB / -86 dB A-weighted
Channel fader @ 0 dB	-84 dB / -86 dB A-weighted

LOUDSPEAKER OUTPUTS

Type	Professional speaker connector
Load impedance:	
MAIN L/R	4 - 8 Ohm
MONITOR/MAIN MONO	4 - 8 Ohm
MAIN MONO/MAIN MONO	4 - 8 Ohm
BRIDGE	8 - 16 Ohm

DSP

Converter	24-bit Delta-Sigma, 64/128-times oversampling
Dynamics D/A	90 dB
Sampling rate	40 kHz
Delay Time	max. 5 secs
Signal run time (Line In > Line Out)	approx. 1.5 ms

DISPLAY

Type	2 x 2-digit, 7-segment LED
------	----------------------------

OUTPUT POWER

RMS @ 1% THD, both channels driven:	
8 Ohm per channel	200 W
4 Ohm per channel	310 W
RMS @ 1% THD, bridged mode:	
8 Ohm	615 W
Peak Power, both channels driven:	
8 Ohm per channel	275 W
4 Ohm per channel	450 W
Peak Power, bridged mode:	
8 Ohm	900 W

POWER SUPPLY

Power Consumption	max. 1000 W
Fuse 100 - 120 V~, 50/60 Hz	T 10 A H 250 V
Fuse 220 - 240 V~, 50/60 Hz	T 6.3 A H 250 V
Mains connector	IEC standard receptacle

DIMENSIONS/WEIGHT

Dimensions (H x W x D)	12.4 in x 18.1 in x 8.7 in 315 mm x 460 mm x 220 mm
Weight	10.3 kg 22.7 lb

PMP960M

MICROPHONE INPUTS

Type	XLR, electronically balanced input circuit
Mic E.I.N. (20 Hz - 20 kHz)	-
@ 0 Ohm source resistance	-112 dB / 114 dB A-weighted
@ 50 Ohm source resistance	-112 dB / 114 dB A-weighted
@ 150 Ohm source resistance	-112 dB / 114 dB A-weighted
Frequency response	< 10 Hz - 200 kHz (-1 dB) < 10 Hz - > 200 kHz (-3 dB)
Gain	+12 dBu @ +10 dB gain
Max. input level	+12 dBu @ +10 dB gain
Impedance	approx. 2.2 kΩ balanced / 1.1 kΩ unbalanced
Signal-to-noise ratio	110 dB / 114 dB A-weighted (0 dBu In @ +10 dB gain)
Noise (THD + N)	0.001% / 0.0007% A-weighted

MONO LINE INPUTS

Type	¼" TS connectors, balanced
Impedance	approx. 20 kΩ, balanced
Max. input level	+21 dBu

STEREO LINE INPUTS

Type	-
Impedance	-
Max. input level	-

EQUALIZER

Low	80 Hz / ±15 dB
Mid	2.5 kHz / ±15 dB
High	12 kHz / ±15 dB

2 TRACK INPUT

Type	RCA
Impedance	approx. 10 kΩ

PREAMP OUTPUTS

MAIN	
Type	¼" TS connectors, unbalanced
Impedance	approx. 150 Ω, unbalanced
Max. output level	+21 dBu
MONITOR	
Type	¼" TS connectors, unbalanced
Impedance	approx. 150 Ω, unbalanced

PMP980S/PMP960M

6/10 x 2 Live Powered Mixers

Max. output level	+21 dBu
-------------------	---------

STEREO OUTPUTS

Type	-
Impedance	-
Max. input level	-
Type	RCA, mono output
Impedance	approx. 1 kΩ
Max. input level	+21 dBu

MAIN MIX SYSTEM DATA

Noise:	
MAIN MIX @ -∞	-102 dB / -106 dB A-weighted
Channel fader -∞	-102 dB / -106 dB A-weighted
MAIN MIX @ 0 dB	-88 dB / -91 dB A-weighted
Channel fader -∞	-88 dB / -91 dB A-weighted
MAIN MIX @ 0 dB	-84 dB / -86 dB A-weighted
Channel fader @ 0 dB	-84 dB / -86 dB A-weighted

LOUDSPEAKER OUTPUTS

Type	Professional speaker connector
------	--------------------------------

Load impedance:

MAIN L/R	-
MONITOR/MAIN MONO	4 - 8 Ohm
MAIN MONO/MAIN MONO	4 - 8 Ohm
BRIDGE	8 - 16 Ohm

DSP

Converter	24-bit Delta-Sigma, 64/128-times oversampling
Dynamics D/A	90 dB
Sampling rate	40 kHz
Delay Time	max. 5 secs
Signal run time (Line In > Line Out)	approx. 1.5 ms

DISPLAY

Type	2-digit, 7-segment LED
------	------------------------

OUTPUT POWER

RMS @ 1% THD, both channels driven:	
-------------------------------------	--

8 Ohm per channel	200 W
4 Ohm per channel	310 W

RMS @ 1% THD, bridged mode:

8 Ohm	615 W
Peak Power, both channels driven:	
8 Ohm per channel	275 W
4 Ohm per channel	450 W

Peak Power, bridged mode:

8 Ohm	900 W
-------	-------

POWER SUPPLY

Power Consumption	max. 1000 W
Fuse 100 - 120 V~, 50/60 Hz	T 10 A H 250 V
Fuse 220 - 240 V~, 50/60 Hz	T 6.3 A H 250 V
Mains connector	IEC standard receptacle

DIMENSIONS/WEIGHT

Dimensions (H x W x D)	12.4 in x 18.1 in x 8.7 in 315 mm x 460 mm x 220 mm
Weight	10.3 kg 22.7 lb

Order via the BEHRINGER 24/7 Dealer Portal or contact the BEHRINGER location nearest you:

BEHRINGER Australia tel.: +61 3 9877 7170, fax: +61 3 9877 7870 **BEHRINGER Germany** tel.: +49 2154 9206 4149, fax: +49 2154 9206 4199 **BEHRINGER Japan** tel.: +81 3 5281 1180, fax: +81 3 5281 1181 **BEHRINGER Singapore** tel.: +65 5845 1800, fax: +65 6214 0275 **BEHRINGER USA / CANADA** tel.: +1 425 672 0816, fax: +1 425 673 7647

behringer.com

